

# NSPB-LV/MV

Total Busduct Solution for Reliable and Efficient Energy Distribution

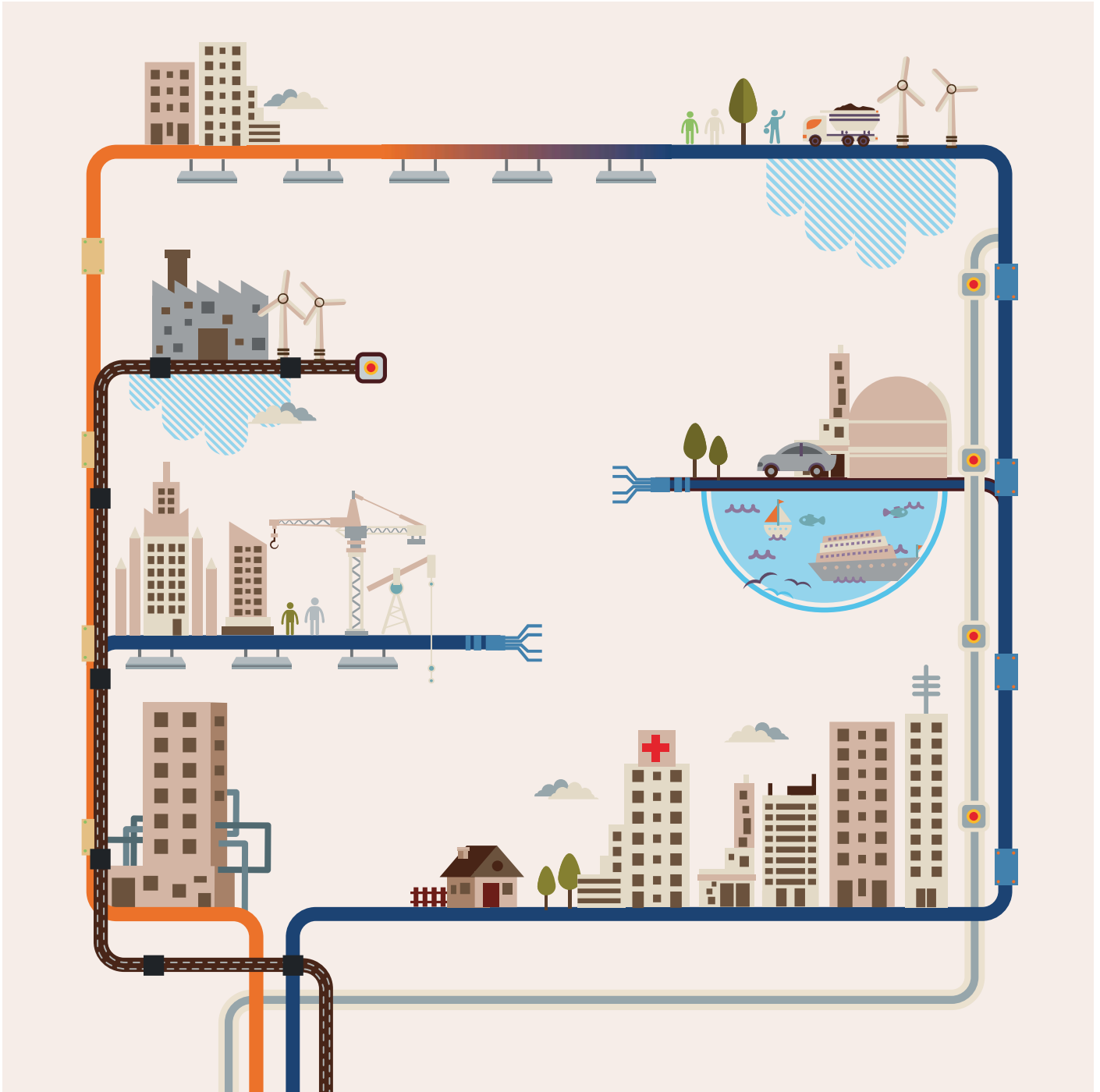



# THE WORLD BEST CABLE SOLUTION LEADER

LS Cable & System supplies various cables and materials used for power grids and communication networks around the world across all industries providing its top class technology and excellent quality. The company has also developed state of the art products, such as superconductors, HVDC and submarine cables that will lead the future energy industry.

**LS spun off from LG in 2003 as a group specializing in electronics, electrical systems, energy and materials.**



**LS** Cable & System

Transmission Cable  
Distribution Cable  
Submarine Cable  
Telecommunication Cable  
Industrial Cable  
Industrial Material

**LS**ELECTRIC

Electric &  
Automatic Equipments

**LS**-Nikko Copper

Copper Refinement

**LS** Mitron

Mechanical &  
Electronic Parts

**yesco**  
LNG

**E1**  
LPG

**GBON**  
Power &  
Communication  
Cables

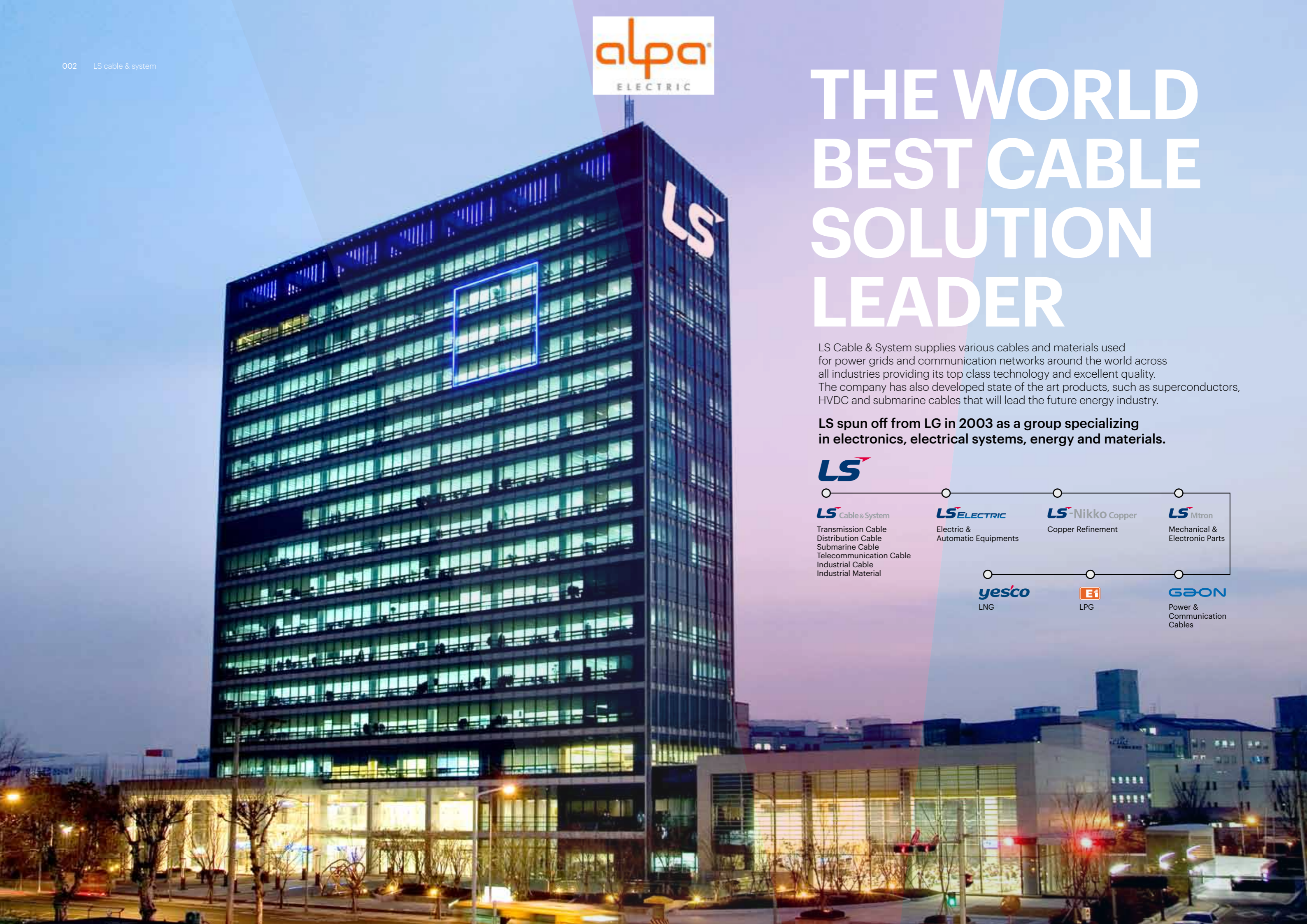



# LS Cable & System Busduct System Solution



### Buildings

The LS C&S Busduct system is easy to install, and ensures large capacity of energy transmission while providing space efficiency which makes the bus duct system ideal for high-rise buildings, office buildings, data centers and apartment complexes.



### Plants

The full lineup is consisting of NSPB, CAST RESIN and SIB that can cover up to 27kv, and the lineup thus enables us to provide our clients customized designs. The system is suitable for electrical rooms and power lines, and it features a real time monitoring system using the temperature and power monitoring system.



### Data Center

The flexibility and expandability as well as easy maintenance property of the busduct system provides the best alternative to improve the existing problems of the conventional power cable system of data centers, which requires constant extension, reinstallation and capacity modification of loads.



### Apartment Buildings

Although the demands for more electricity for families are growing, the space for EPS area has reduced. Due to the change, the need for busducts and multi boxes have increased.



### Hospitals

The stability of the power supply in the hospitals is perhaps the most vital element, because its failure could threaten the safety of patients. The Busduct system distributes larger capacity of electric power, and provides stability of the loads which make it an ideal choice to satisfy the requirements of systematization of hospital complexes and larger hospital equipments.



### Airports

In order to secure the stable power supply of the airport, the busduct system provides the best customized solutions by installing high voltage busducts at the transmission, transformation and power distribution lines, and by installing low voltage busducts at the cargo, the control tower and general commercial buildings.



### Stadiums

The needs for a busducts system has been growing for its benefit such as large capacity of power transmission, providing a stable power supply for various loads and an eco friendly property as well as economical quality.



### Marine & Wind

The compact and light weight design of the busduct satisfies the demands of the clients, and comes with an outstanding quack resistance property. The busduct provides stability to the operation of the facilities through a real-time monitoring system using a temperature and power monitoring system. As the needs for renewable energy grows, the demand for our busduct has been increasing steadily.

# LS Cable & System Busduct Product Line-up

The LS Cable & System Busducts are available in a wide range of products from low current capacity LT-way (25A~63A) to large current capacity (630A~7500A), and the products enable the supply of proper capacity of power for factories and the distribution system. Our products such as the air insulated bus conducts with enhanced safety property and the cast resin busducts with resistance for high temperature, humidity and dusty environment will satisfy various application needs and provide a customized engineering service.

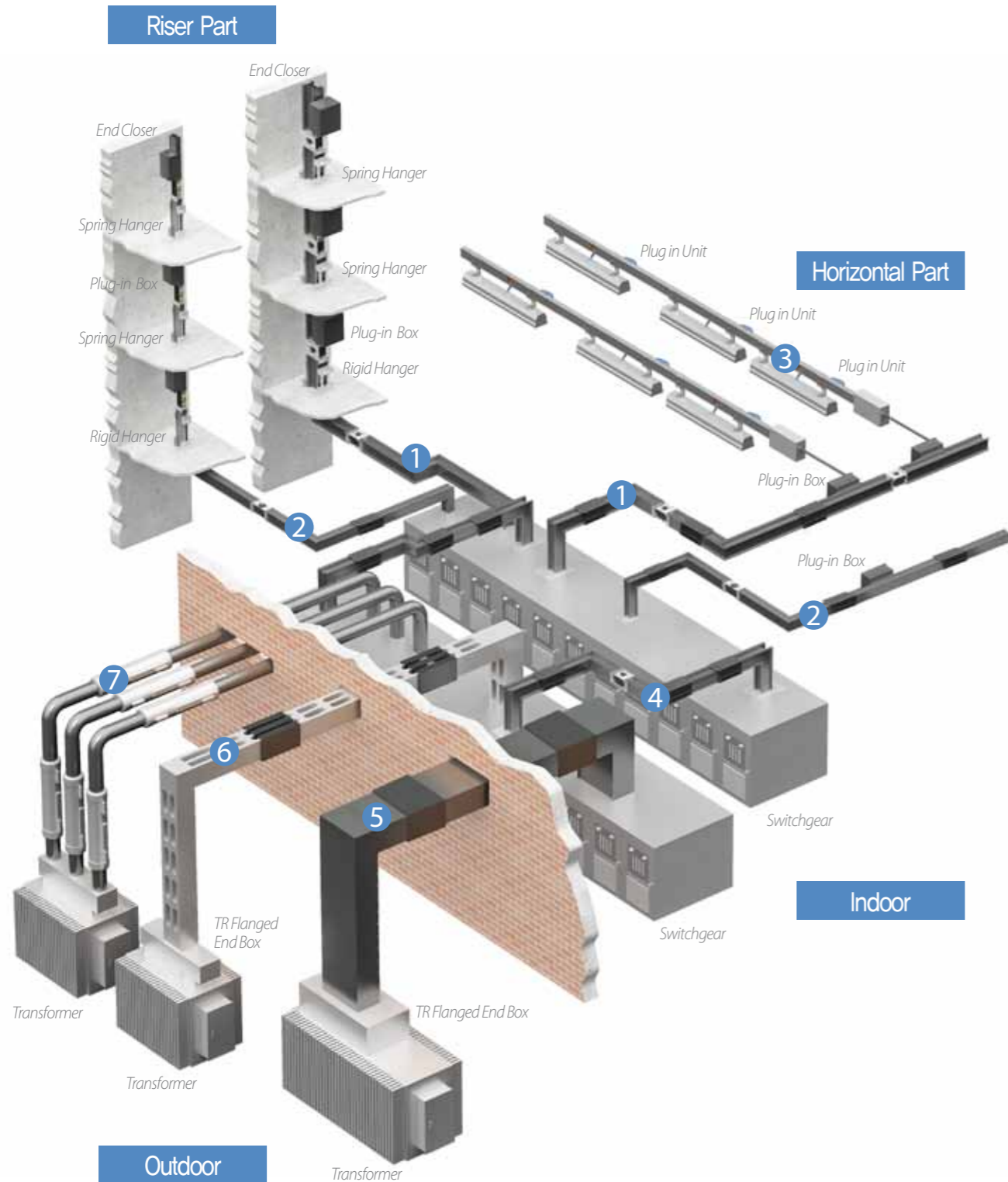

		<p><b>Ez/Ex/Ef-way</b></p> <p>Sandwich Type (PET Film, Epoxy Coating, MICA)/AL Extrusion Housing/Standard IP54/Joint Kit</p> <ul style="list-style-type: none"> <li>- Designed for low voltage products below AC 1000V, and between 630A to 7500A.</li> <li>- The most widely used conventional model.</li> </ul>
		<p><b>Mini-way</b></p> <p>Air Insulated Type/AL Extrusion Housing/Standard IP54/Joint Kit</p> <ul style="list-style-type: none"> <li>- Designed for low voltage products below AC 1000V, and between 160A and 800A.</li> <li>- Ideal for small distribution system with multi distribution loads (Vertical areas of buildings, data centers, assemble factories)</li> </ul>
		<p><b>LT-way</b></p> <p>Flat Wire Type/Copper Conductor with PVC Extruded Insulation/AL Extrusion Housing/Various Plug Types/Joint Brush (It can be installed with a live wire.)</p> <ul style="list-style-type: none"> <li>- Designed for low voltage products below AC 690V, and between 25A and 63A</li> <li>- Suitable for Light bulbs, FFU and distribution for small equipments</li> </ul>
		<p><b>MS/Wind-way</b></p> <p>Air Insulated Type/ Compact NSPB Type / One-Bolting Type</p> <p>Designed for low voltage products below AC 1000V, and between 1000A and 5000A</p> <ul style="list-style-type: none"> <li>- A Hybrid incorporating NSPB and sandwich type</li> <li>- Ideal for ships, wind towers and chemical plants where stability is required.</li> </ul>
		<p><b>NSPB-LV/MV</b></p> <p>Air Insulated Type/Insulated conductors separated by phase/AL, STS and Steel Housing (optional)/Indoor Type/Outdoor Type</p> <ul style="list-style-type: none"> <li>- NSPB-LV : Designed for low voltage products below AC 1000V, and below 4000A</li> <li>- NSPB-MV: Designed for high voltage products below AC 27kV, and below 4000A</li> <li>- Suitable for plants where high stability is required.</li> </ul>
		<p><b>CR-LV/MV</b></p> <ul style="list-style-type: none"> <li>- Cast Resin Type/IP 68/Epoxy Molding between Conductors</li> <li>- CR-LV: Designed for low voltage products below AC 1000V, and between 630A and 7500A.</li> <li>- CR-MV: Designed for high voltage products below AC 27kV, and below 5000A.</li> <li>- The most safe bus duct suitable for plants where high stability is required.</li> </ul>
		<p><b>SIB</b></p> <p>Epoxy Vacuum impregnated insulation Products/Suitable for phase separation system</p> <ul style="list-style-type: none"> <li>- Designed for high voltage products below AC 27kV and below 7500A</li> <li>- Small space , bending area</li> <li>- Suitable for high voltage products.</li> </ul>

# Why Busduct?

## Easy Distribution of Loads

When supplying power using cables, each load has to be connected individually to cables which waste space, and an additional distribution panel is also required. On the other hand, busducts are separated from a single line at a plug box which simplifies the electric power system. A MCCB can be installed at the plug box to effectively shut off fault current.

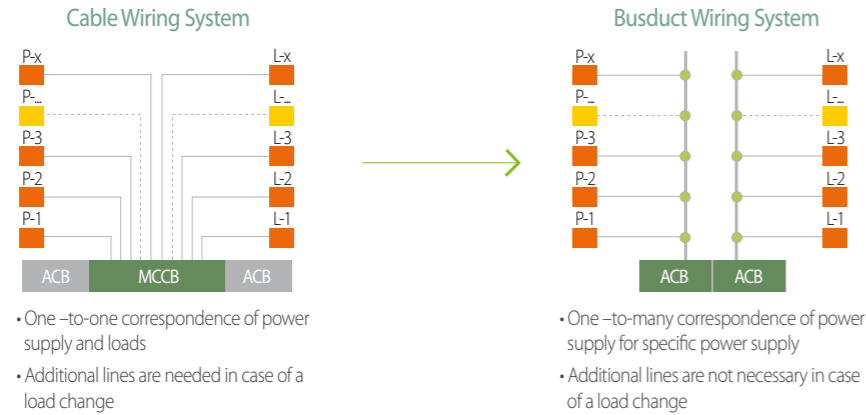

ACB: Air Circuit Breaker, MCCB: Molded Case Circuit Breaker

## Easy Installation

Pulling and cable tray installation for cables can be difficult, and requires a longer construction period, therefore increases the cost. On the other hand, the busducts use a simple installation method to connect specific length of products, which requires a shorter installation period, and is economically friendly.

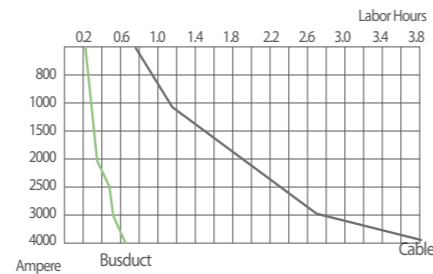

## Compact

The compact design of the busduct system provides high space efficiency at up to 50% compared to the cables. While cables require larger space to install multi lines as well as additional space for coiling areas, the busducts use proper fittings to maximize space efficiency.

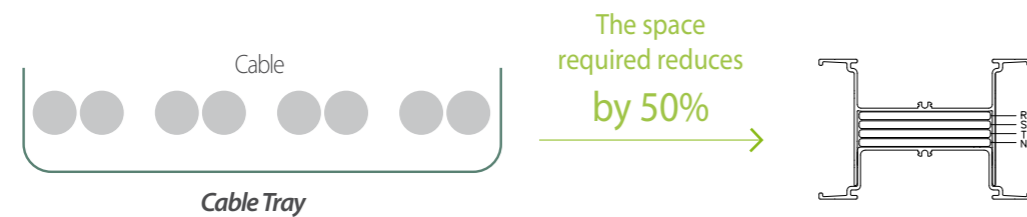

## Adaptability to various installation environment with convenience

The busduct system is a power distribution system and can be applied to various complex routes. The busduct system comes with various fittings such as elbow, off-set and tee, and can transmit high capacity currents without electrical and mechanical loss.

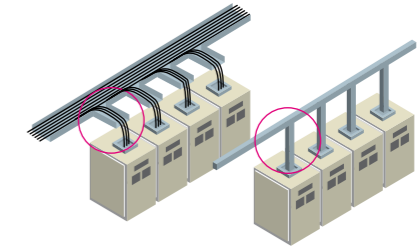

## Excellent short circuit strength

The busduct system has a high tolerance for short circuit. Its stability and reliability make it perfect for a high capacity energy transmission system.

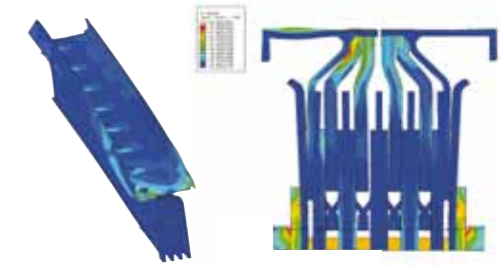

## High current density

Cables are connected directly to electric loads using racks. Its maximum allowable current ampacity limit is 1000A, and requires additional lines for a higher current. Each line of the busduct system can transmit up to 7500A, and provides high current density.

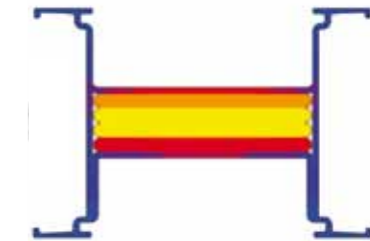

## Easy maintenance

The design of the busduct system makes it easy to detect abnormalities during installations, and ensures easy maintenance. When humidity or dust causes a malfunction on the system, the easy-to-maintain design allows replacing only the damaged part.

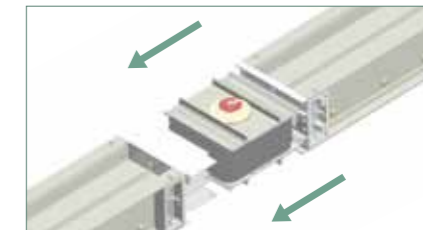

## Outstanding features of EMC and EMI

Unlike cables, the busduct system does not require a shield, instead Busduct, the housing itself performs as a shield which enhances the features of EMC and EMI.



# Why LS Cable & System Busduct

## Global Top Tier

LS Cable & System has been a long-time leading Busduct provider in Korea. With extensive experience and product line competitiveness, the company provides total solutions for each application to satisfy the needs of its clients. Using its expertise in the electronic markets of large LCD monitors and semiconductors in Korea, the company has obtained PJT sales records in 50 countries worldwide in Asia, the Middle East, CIS, and America.

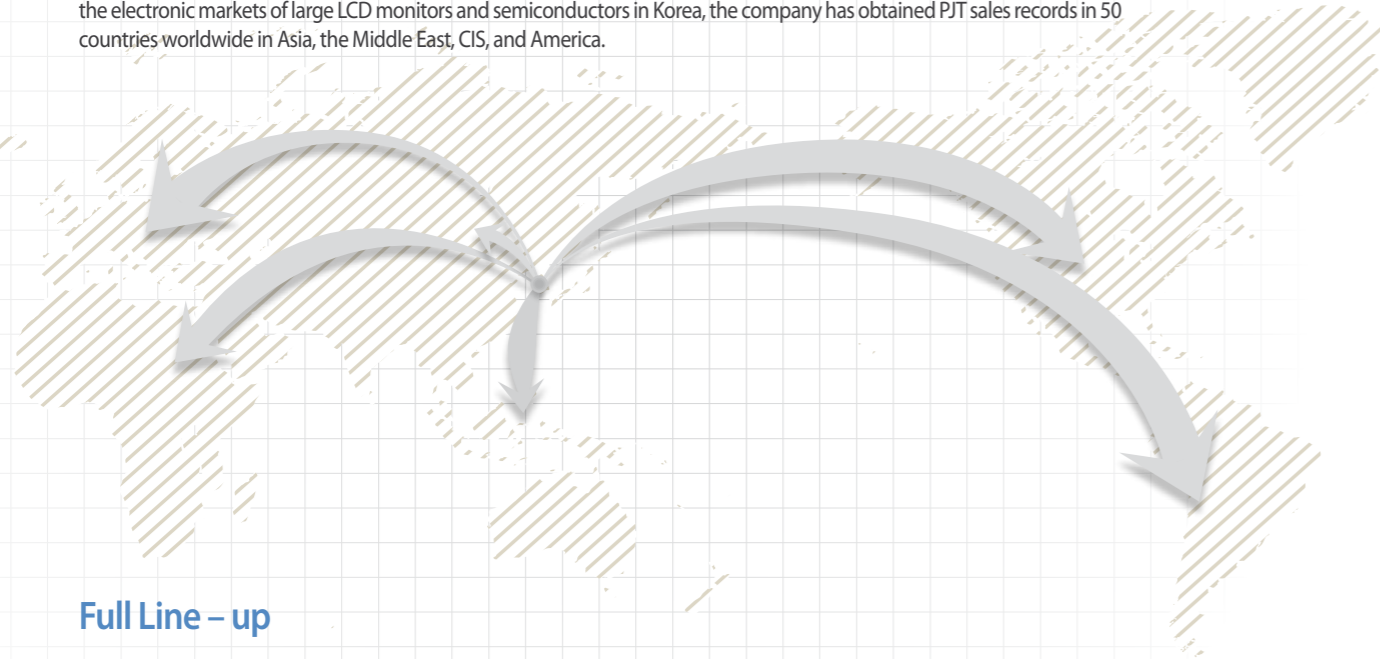

## Full Line – up

LS Cable & System is the only global company that provides a full line-up of busducts, from low to high voltage and from low to high capacity, to satisfy every need of its clients and provide an optimized solution for each PJT.

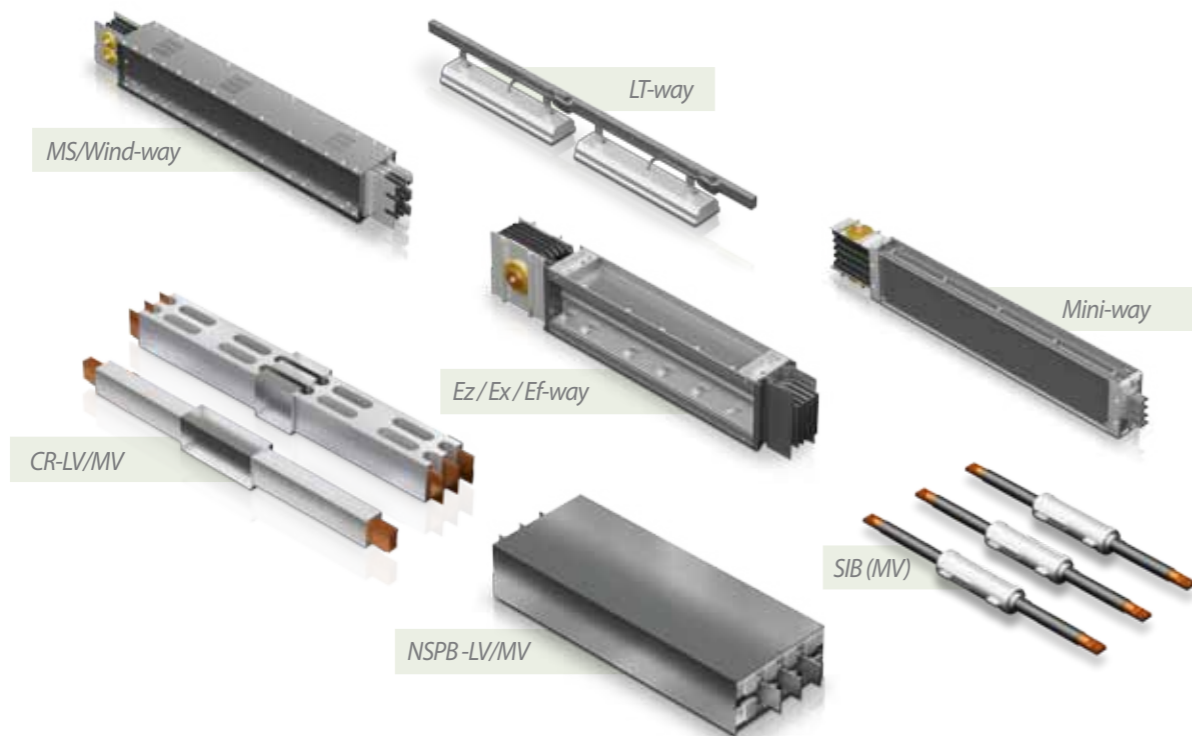

## Total Solution

- Once PJT launches, our engineer will participate to guide the clients from the initial period in order to produce the best system for our clients, and to respond quickly when the system is changed.
- Our engineers from each department provide full support in design, production, installation and testing at in-bound to satisfy our clients.
- We operate the CS Team, a task force for the busduct system, to make sure efficient after-sale service and maintenance service.

## Process

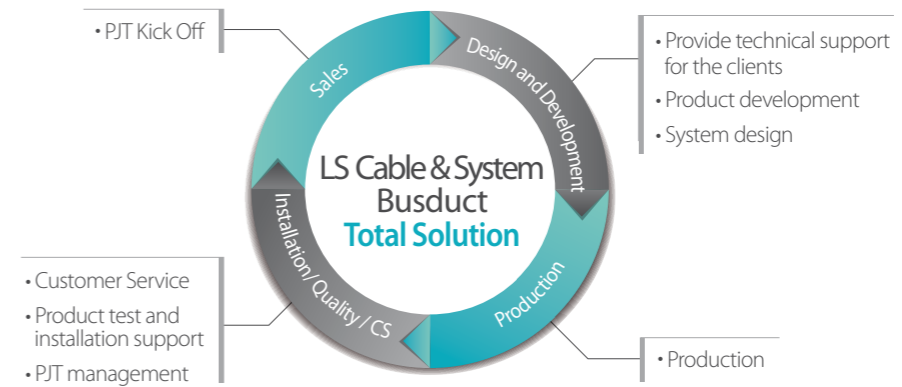

## Technical Excellence

### Unparalleled Reliability

- Provides standardized design, and owns numerous certifications such as UL Certification, Quack Proof Certification, and Impact Resistance Certification
- The CS team, a task force for the busduct system, provides efficient after-sale service
- Safe use in hazardous zones
- Manage the system using a unique temperature monitor sensor
- Semi-permanent service life
- Used qualified insulation such as epoxy and PET film for efficient insulation

### Eco friendly

- Fully recyclable
- Halogen free
- Does not contain RoHS 6 hazardous substance
- No toxicity in fire & Fire-Retardant
- Non Explosive

### Total Engineering Technology

- Provide the optimal design by experienced engineers
- Design following analysis and inspection of CAE
- Unique and exclusive design program for the busduct system
- Design based on structure stability inspection
- The excellent heat –radiating property of the aluminum housing, which ensures large capacity of power transmission
- Low Weight & Low cost
- Easy installation
- Deployable where access is difficult
- Automated epoxy insulation facility
- Unique joint kit connections
- Reduce electromagnetic
- BPMS (Busduct Power Monitoring system)
- BTMS (Busduct Temperature Monitoring system)

# Why LS Cable & System Busduct

## The Busduct Temperature Monitoring System (BTMS : Busduct Temperature Monitoring System)

The busduct is a large capacity power distribution system. The insulation of the duct has to stay stable when the Joule lines occur during a power supply of the conductor. The rated current will be set by the insulation type and the temperature rises. These properties of the busduct make it possible to monitor and manage abnormalities of the system by checking the temperature of specific areas of the system.

The temperature monitoring system uses various temperature sensors such as optical fiber cable, IC electric chips and thermo-graphic cameras. Specific areas like the entire system line, joints, plug-in boxes and cable connection can be monitored at the central monitor room using various methods on request.

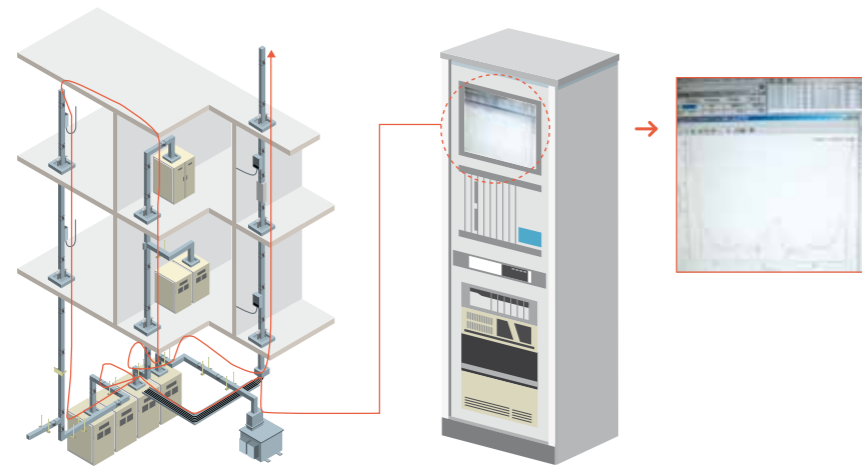

## The Busduct Power Monitoring System (BPMS : Busduct Power Monitoring System)

The ongoing trends of the busduct system are more than a simple power supplying system. The growing trend is; 1) the stability of the power system, 2) unmanned system, 3) cost cutting, and 4) green and smart grid. While the SCADA system monitors and controls the power of the main system, the BMS monitors low loads of the sub system. The frequency of the recent electrical accidents is higher at the sub system than at the main system. Therefore, the preference for the BMS system has been increasing.

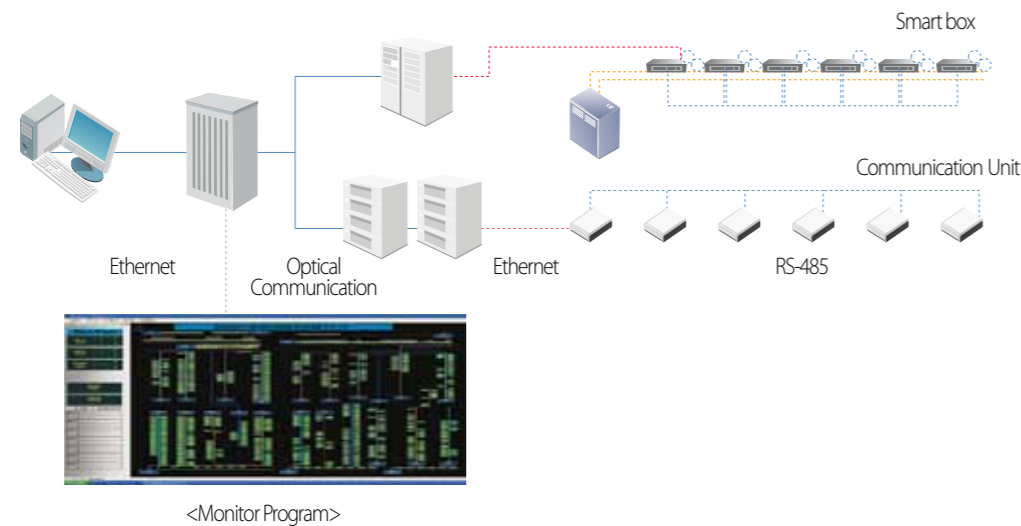

# NSPB-LV/MV

LS C&S Busduct System Catalogue

05 of 08

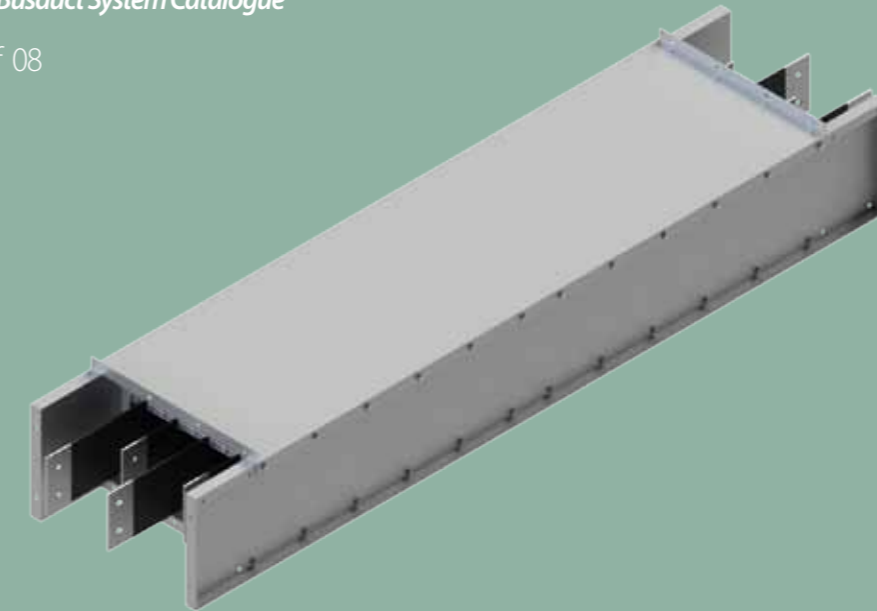

## Contents

<b>I. Introduction</b>		
- Overview	14	
- Application	15	
- Customized Engineering	16	
		<b>LV MV</b>
<b>II. General Data</b>	20	28
<b>III. Component</b>		
- Feeder	21	30
- Fittings	22	32
- Hanger	23	35
<b>IV. Install Information</b>	25	36
<b>V. Technical Data</b>	26	37
<b>VI. Certification &amp; Specification</b>	38	
<b>VII. Busduct Major References</b>	39	

# Overview

## The NSPB

The design of the LS C&S NSPB Busduct improved the stability of the system by incorporating the epoxy coating and air insulation. The Busduct is available from a low voltage of AC 1000V or less, up to a high voltage of 27kV. It is suitable for current capacities between 800A to 4000A. The Busduct comes with a class B rating (130°C) insulation and its water proof quality is suitable for outdoors.

## Safe and Efficient Distribution System

The LS C&S NSPB Busduct is designed for large plants as they are becoming larger. The extensive experience and the proficient engineers of LS C&S provide high-performance products. The efficient design ensures the products to harmonize with structures, and the property of the products does not interfere with existing equipments.

## Environmentally Friendly and Excellent Performance

The LS C&S NSPB Busduct acquired RoHS certification, and uses components without hazardous substances such as lead, cadmium, mercury, chrome, PBBs and PBDEs. The design of cross sectional areas of the conductors, supporting structures and the housing are in accordance with the standard of IEC and IEEE. It also has high short circuit strength.

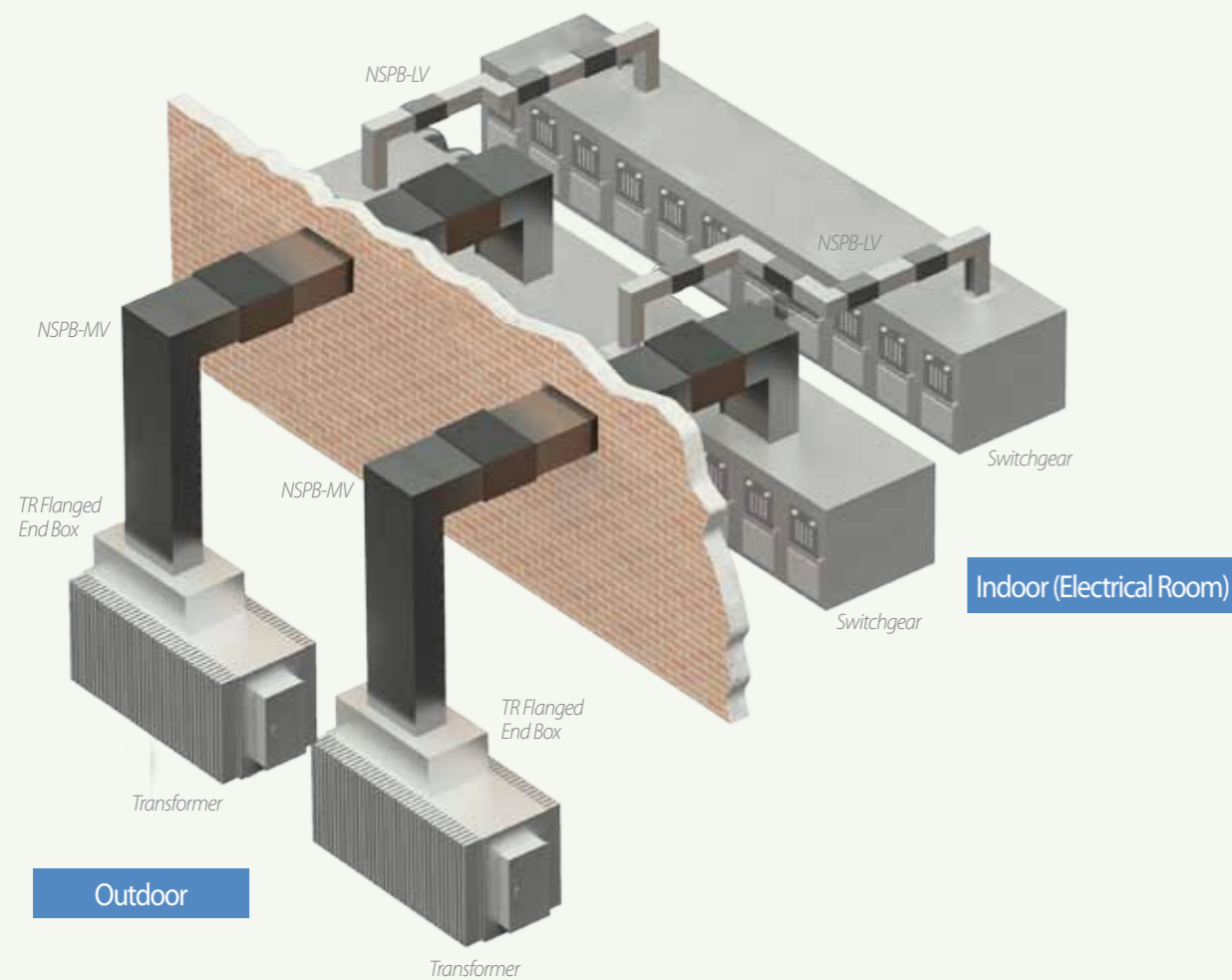

# Application

## High Rised Building etc.

- Main electric rooms where large capacity of power transmission is required

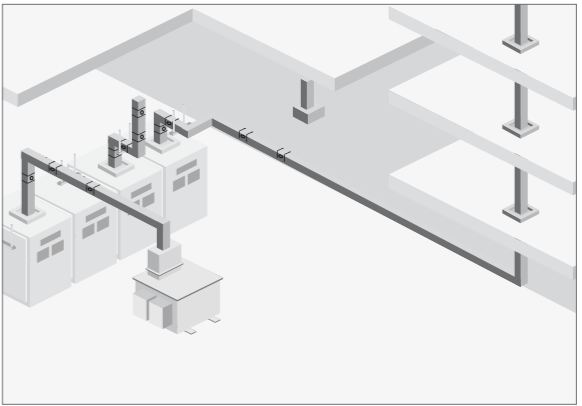
## Oil & Gas etc.

- Due to the use of chemicals, safety is the top priority of plants



## Steel and Smelting etc.

- Transmission of high voltage and large capacity of power

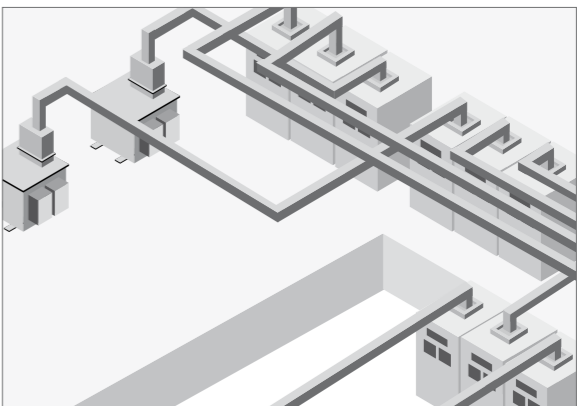

# Customized Engineering

The company provides a wide range of options including conductors, materials and design of housing as well as products for various range of voltage (27kV or less) and current (between 800A and 4000A) to satisfy the needs of the clients and their specifications.

## 01 Standard

The specialists of the company will provide the ideal size of the conductors and products through tests and analyses as specified in CAE to satisfy specific needs of clients.

### Configuration

#### LV

- IEC 61439-6 [(previous standard) IEC 60439-2] Busbar Trunking Systems
- IEEE C37.23 IEEE Standard for Metal-Enclosed Bus

Specifics	IEC	IEEE
Voltage level	1000V or less	0.635kV or less
Temperature Rise	35°C	40°C
	<ul style="list-style-type: none"> <li>• Housing : 55K</li> <li>• Conductor : 70K</li> </ul>	<ul style="list-style-type: none"> <li>• Housing : 40K</li> <li>• Conductor : 65K</li> </ul>
	The specifics can be adjusted according to the heat resistance values of the insulations. Ex. Insulations with a heat resistance value of 130°C can be used with conductors with a maximum of 95K.	

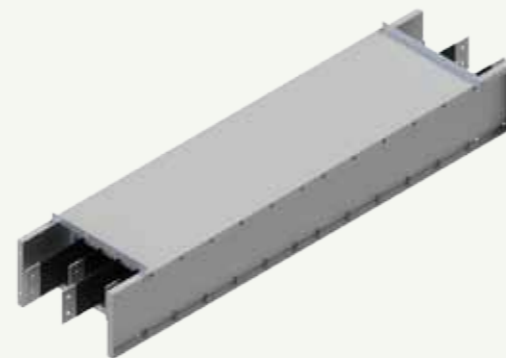

#### MV

- IEC 62271 High-voltage switchgear and controlgear Part 200 : AC metal-enclosed switchgear and controlgear for rated Voltages above 1 kV and up to and including 52 kV
- IEEE C37.23 IEEE Standard for Metal-Enclosed Bus

Specifics	IEC	IEEE
Voltage level	7.2(20) 12(28) 17.5(38) 24(50)	4.760(19) - 15(36) 27(60)
Ambient Temperature	35°C	40°C
Temperature Rise	<ul style="list-style-type: none"> <li>• Housing : 55K</li> <li>• Conductor : 70K</li> </ul>	<ul style="list-style-type: none"> <li>• Housing : 40K</li> <li>• Conductor : 65K</li> </ul>
	The specifics can be adjusted according to the heat resistance values of the insulations. Ex. Insulations with the heat resistance value of 130°C can be used with conductors with a maximum of 95K.	

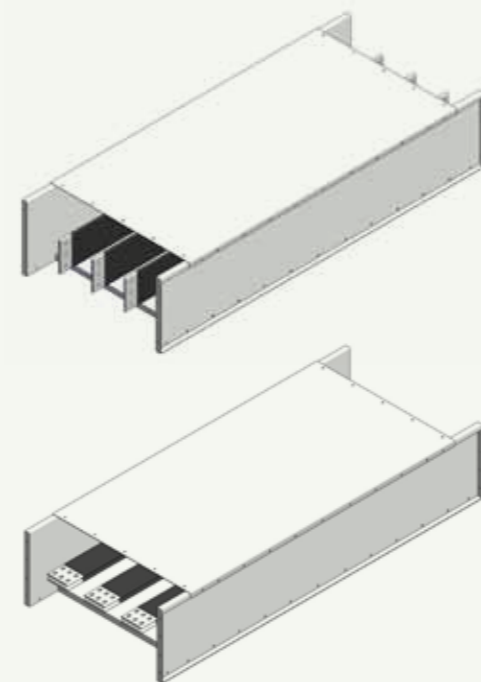

## 02 Conductor Materials

The NSPB Busduct uses either copper conductors with conductivity over 99%, or aluminum conductors with conductivity over 54%. The connection of the conductors is tin-plated in order to reduce contact resistance and to prevent corrosion of the connection. (A silver plated option is available.)

## 03 Conductor Insulations

The NSPB Busduct comes with standard epoxy coating, however, tube insulations is available on request. Epoxy coating is applied by automated facility. The company performs rigorous testing on the products including exterior of the conductors, coating thickness, pin holes, impacts and flexibilities to provide products that are highly safe.

## 04 Alignments and Size of Conductors

The alignment of the conductors can be chosen between vertical or horizontal alignments to provide the optimized structures and size to satisfy the installation environment and the specifics of the requests.

### ✓ Note

The optimized heat-radiating structure and size of the conductors are chosen through simulation and actual measurement tests including heat-radiating mechanism of the conductors, coating effects, housing materials and the location of the grounding bar. (The size of the conductors can be reduced when the conductors are aligned vertically in comparison to horizontally aligned conductors.)

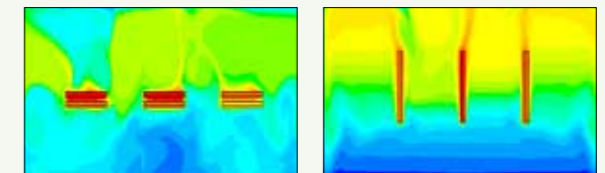

## 05 Housing Materials

High strength aluminum (50 type), STS, steel or materials with either the same or higher mechanical strength are used for housing of the NSPB Busduct. Therefore, the mechanical strength and the heat-radiating property of the housing are excellent. The standard color of the coating is 5Y 7/1, however, the company provides a wide range of color to satisfy the needs.

### ✓ Note

The 3 types of current supply loss of metal materials are shown below.

- 1) Hysteresis loss (iron loss)
- 2) Eddy-current loss (induced current loss)
- 3) Copper loss.

These losses eventually increase loss resistance. Compared to the characters of steel, a ferromagnetic body and high permeability, using aluminum and STS decreases the loss from magnetic flux caused by time variation of the current.

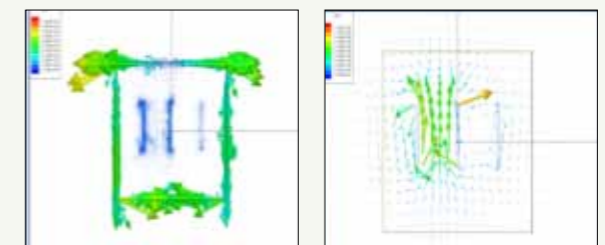

# Customized Engineering

The company provides a wide range of options including conductors, materials and design of housing as well as products for various range of voltage (27kV or less) and current (between 800A and 4000A) to satisfy the needs of the clients and their specifications.

## 06 Insulation Support

Using insulations (LV: engineering plastic, MV: epoxy type) with dielectric strength in correspondence with voltage ensures the insulation property of the housing. In order to obtain the stable installation and sufficient functionality of the conductors, the insulations are located at ideal intervals based on analysis of CAE (Computer Aided Engineering).

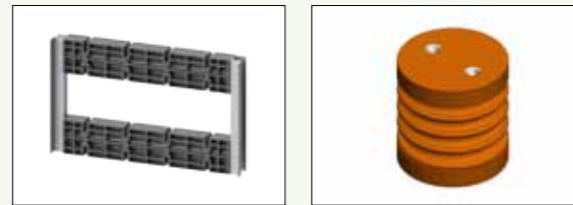

**Note**

There are 3 types of air insulation busducts. (IEEE Std C37.23: IEE Standard for Metal-Enclosed Bus Standard) LS Cable & System provides the NSPB type, however, other types are available to satisfy the needs, or for special environments. (Please contact our design team for further information.)

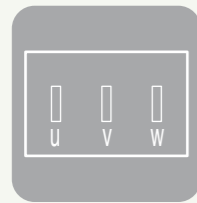

**NSPB (NonSegregated Phase Busduct)**  
Each phase conductor of the busduct at a single housing is separated by the voltage, and the conductors are supported by either insulators or insulations. The NSPB is suitable for high voltage or extra high voltage lines of substations.

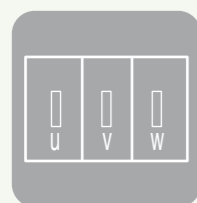

**SPB (Segregated Phase Busduct)**  
Each phase conductor of the busduct at a single housing is separated by the voltage, and the conductors are supported by either insulators or insulations. However, barriers are installed between the phases to separate them.

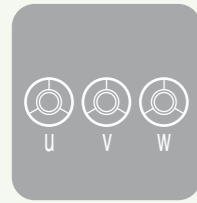

**IPB (Isolated Phase Busduct)**  
The air insulated conductors of the busduct are fixed by insulation supports, and wrapped separately in tubes by phase. The busduct is a phase separator for power plants that transmits large capacity of power at the centerline of a generator and the main and auxiliary transformer of a power plant.  
\*LS Cable & System does not produce IPB type products. Instead, the company provides SIB type products that are similar to the IPB type. (Please contact our sales team for further information.)

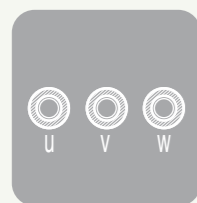

**SIB (Solid Insulated Busduct)**  
Each phase conductor is completely insulated separately with an epoxy vacuum impregnated method, and they are wrapped with protection tubes. Each phase tube is separated by air bound.

## 07 Options

Grounding, Space heaters, Vents, Drain hole, Vapor Barrier/Fire Barrier, Sunshade

### Grounding

The standard aluminum housing of the NSPB is designed to perform as a grounding conductor without additional conductors. (Additional ground bars can be added on request. Please contact our design team for further information.)

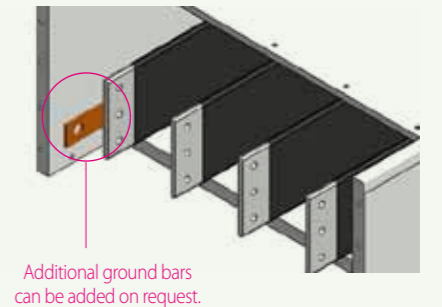

### Space Heaters

A space heater can be applied for outdoor products to reduce dew condensation. The heater is installed inside of the product during production. A temperature sensor or a humidistat can be applied along with the heater for better control. A space heater set is installed for each feeder as the standard installation.

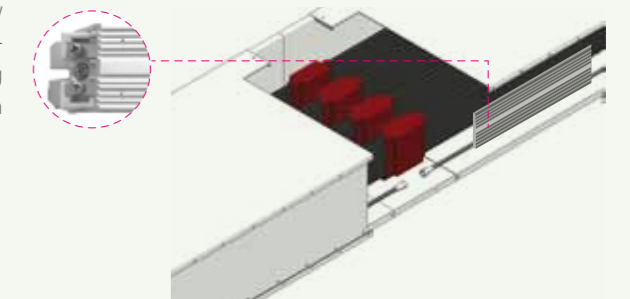

### Vents and Drain Holes

Vents and drain holes are installed to control the air flow of the interior and exterior of the product in order to minimize water leakage and dew condensation, and to discharge moisture during operation. It is designed to prevent the moisture from penetrating by installing vents on the side and drain holes on the bottom.

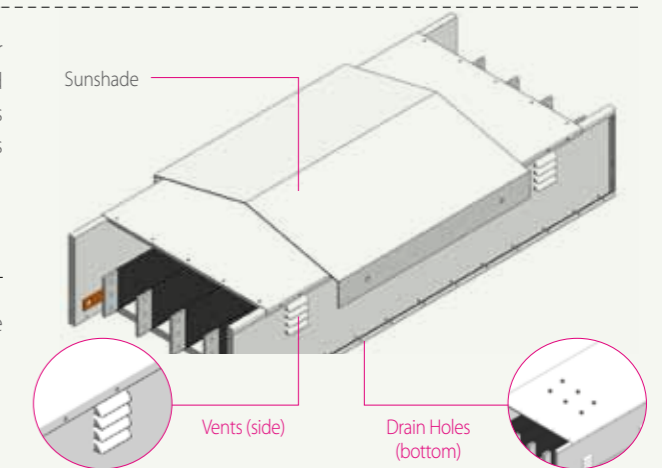

### Sunshade

It blocks out direct sunlight and prevents corrosion and damage to the enclosure from snow and rain.

### Fire Barrier

In order to prevent fire from spreading through the product, refractory materials have been applied at the wall penetration (indoor and outdoor). The barriers also block flames from penetrating into the product.

### Vapor Barrier

A vapor barrier is installed to block the air flow at the wall penetration (indoor and outdoor). It also blocks the interior of the product using an epoxy plate.

## LV Basic Structure

The NSPB-LV uses epoxy insulating material (thermal class 130°C) to separate the phases, and secure them using high strength engineering plastic. It can be applied to 1000V or less, or between 800A and 4000A.

### Structure

- Al/ST3/SPCC
- CU or AL

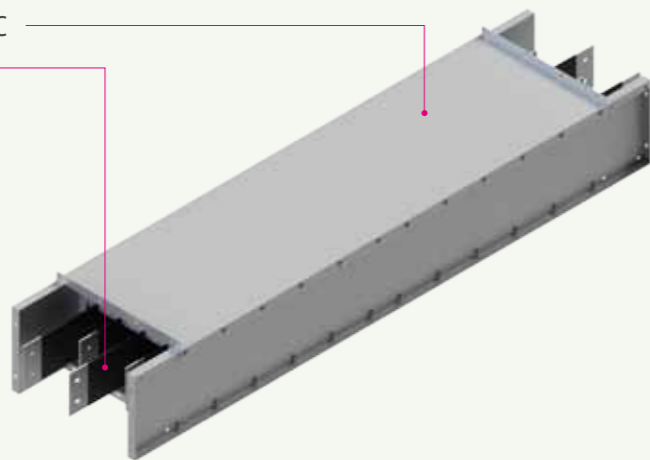

Sectional View

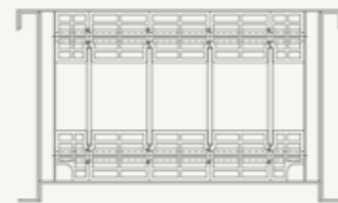

### Joint Cover

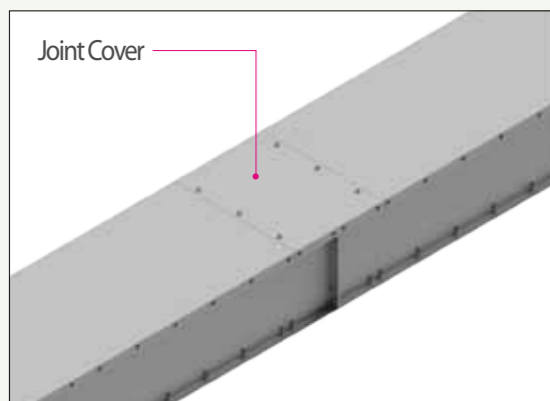

Indoor

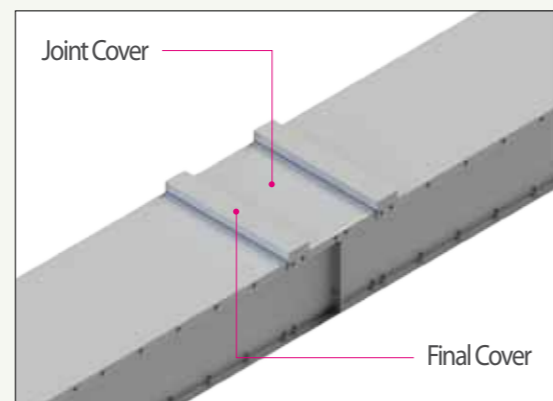

Outdoor



Note

The NSPB is a hybrid type Busduct that combined the benefits of the epoxy insulation type and the air insulation type. Although it provides better insulation stability, it is larger and the cost is higher than the E-Series (sandwich type). Therefore, they are suitable for large plants where the stability is priority.

## Feeder

Although the standard length of the LS C&S NSPB-LV Busduct is 2 meters, it can be adjusted to the installation environment and on request.

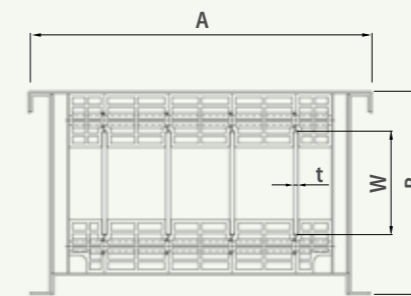

[NL-1-1]

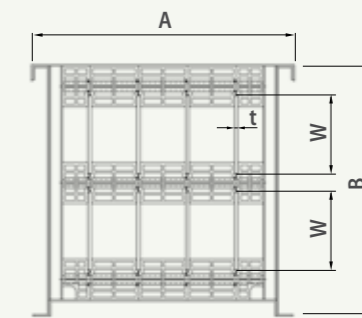

[NL-1-2]

Ampere(A)	Busbar		3W		4W		5W		Fig.
	t	W	A	B	A	B	A	B	
1,000	6.35	57	390	170	480	170	570	170	NL-1-1
1,250	6.35	73	390	186	480	186	570	186	
1,600	6.35	108	390	221	480	221	570	221	
2,000	6.35	145	390	258	480	258	570	258	
2,500	6.35	195	390	308	480	308	570	308	
3,200	6.35	108	390	361	480	361	570	361	NL-1-2
3,600	6.35	126	390	397	480	397	570	397	
4,000	6.35	145	390	435	480	435	570	435	
5,000	6.35	195	390	535	480	535	570	535	
6,000	10	200	390	545	480	545	570	545	

\* Since the standards of the conductors differ, these are only for reference, and they can be adjusted according to the installation site, or on request. (For using aluminum conductors, please contact our design team for further information.)

## Flanged End

The flanged end is used at a transformer or at a low-tension panel. (Please, contact our design team for further information.)



## Fittings

LS C&S NSPB has a wide range of fittings to satisfy any layout of buildings. Elbow angles other than ninety degrees are also available. Offsets or tees can be applied where the standard elbows are not feasible. (Please contact our design team for detailed information about the product length.)

### Elbow

Vertical

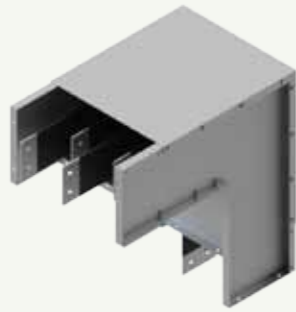

Horizontal



### Offset

Vertical



Horizontal

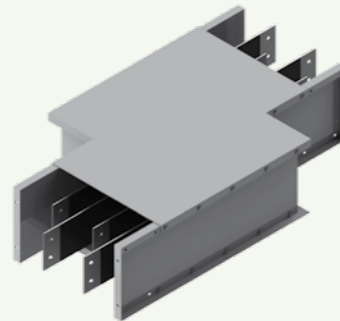

### Tee

Vertical

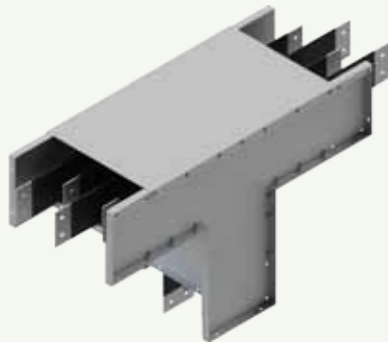

Horizontal

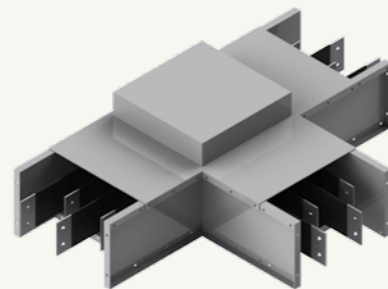

## Hanger

LS C&S NSPB can be installed using horizontal hangers, vertical hangers and wall brackets according to the installation environment. (Please contact our design team for detailed information about installation.)

### Horizontal Hangers

For horizontal installation, the NSPB requires two or more supports for each product.

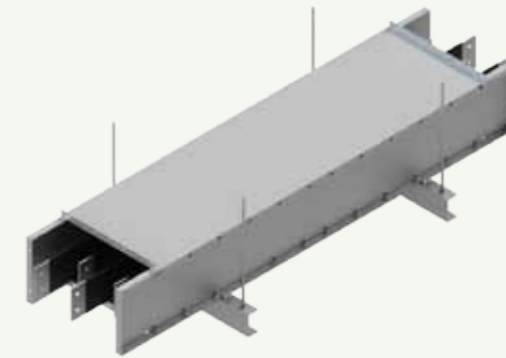

### Vertical Hangers

An additional reinforcement design provides stability for the vertical loading of the vertical feeders.



### Wall Bracket

Once the angles and the channels are applied on walls, they need to be fixed with bolts.

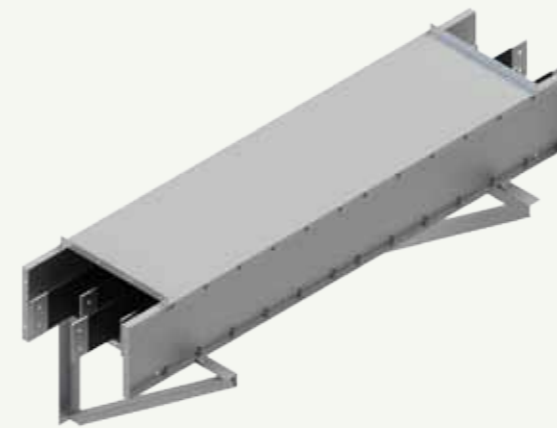

### Beam Support

It is supported on the post.



## Etc.

### Wall Flange

A wall flange is used to seal the gaps produced during installation of busducts at the walls, ceilings and floor.  
The standard dimensions of a wall opening should be 30mm larger than the external dimensions of the NSPB Busduct.

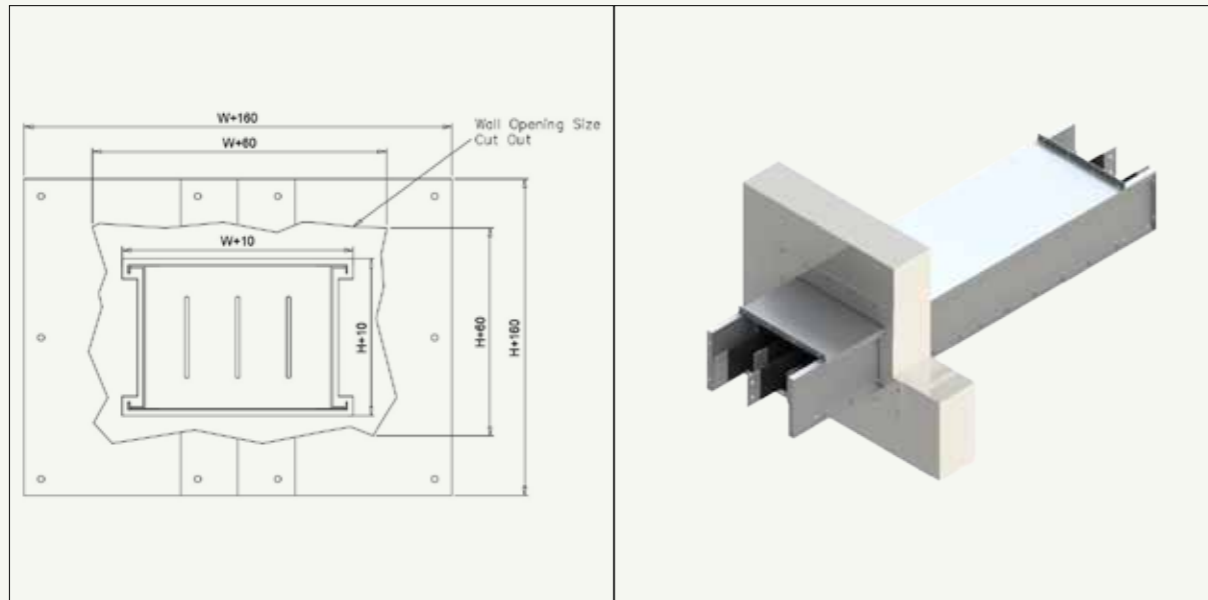

### Floor Openings

The standard dimensions of a floor opening should be 30mm larger than the external dimensions of the NSPB Busduct.

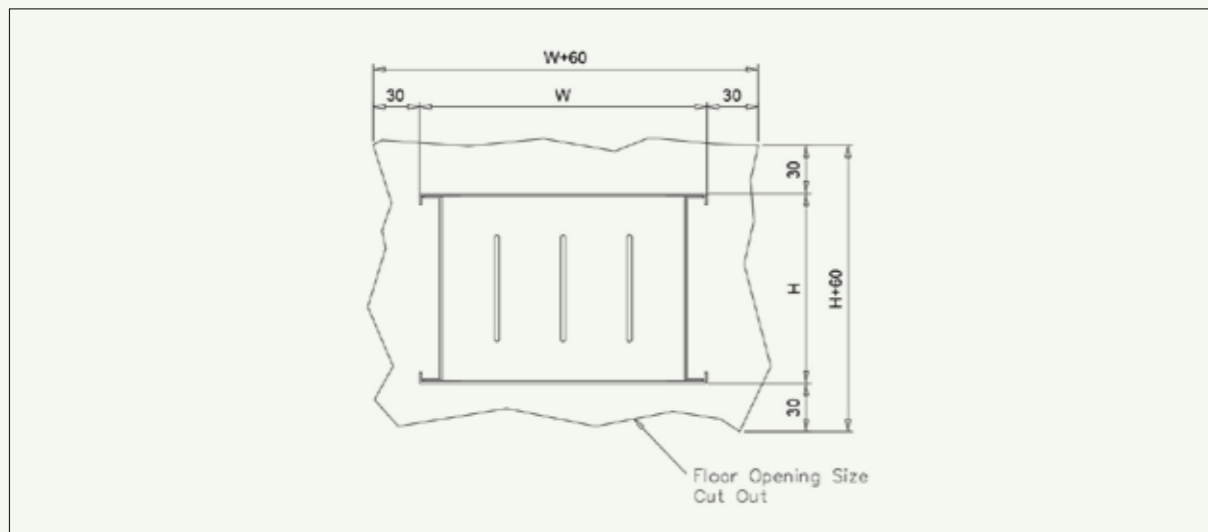

## The Joint of NSPB-LV

### STEP 1.

- The Busducts should be aligned at the top and the bottom and the left and the right as well as horizontally and vertically. Make sure that the surface is clear of dust before connecting them.
- Connect the Busducts by using joint plates and HT bolts as shown in the image. Tighten the bolts until the eye-marking is visible.
- Once they are connected, check for gaps between the bus bars and the joint plates using a feeler gauge.

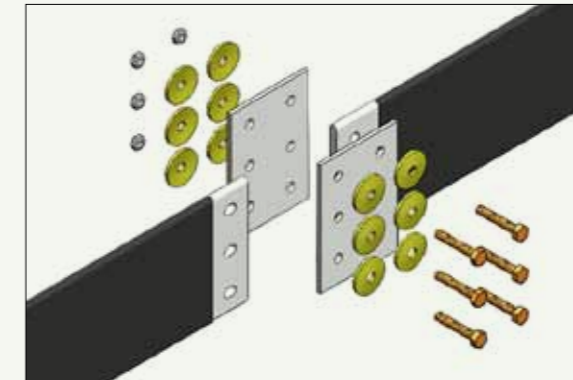

### STEP 2.

- For the NSPB-MV, apply boots additionally after joint plates have been connected as shown in the image.

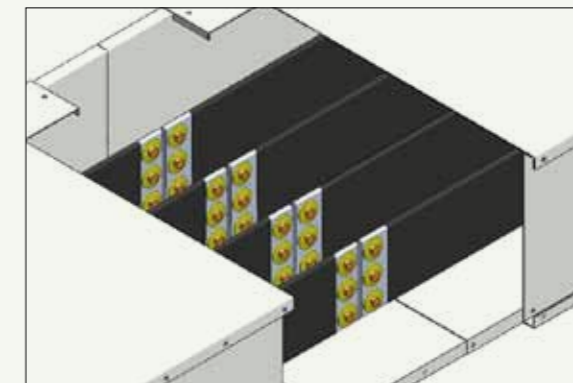

### STEP 3.

- For outdoor installation, apply the top and bottom joint cover and reinforcement covers. Apply silicone at both sides of the covers as shown in the image. (Torque = 120 kgf-cm)

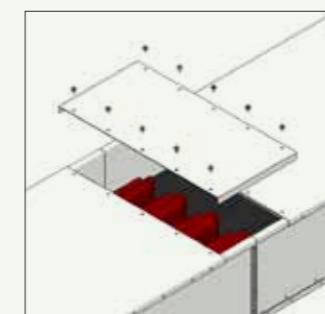

Indoor Type

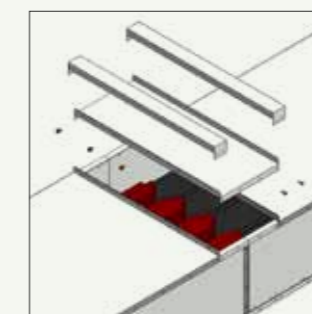

Outdoor Type

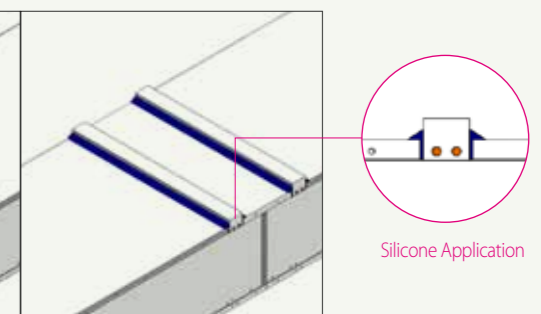

Silicone Application

# Technical Data

## Impedance and Voltage Drop

The formula to measure the voltage drop of a busduct is shown below. The impedance and voltage drop values for aluminum and copper conductors are shown in the table below. The values listed are measured between upper and middle lines at 50Hz.

$$V_d = I \times \sqrt{3(R \cos\theta + X \sin\theta)}$$

$V_d$  = voltage drop[V] · I = rated load amperes[A] · R = resistance[Ω] · X = reactance[Ω] / cos = power factor / sin = reactive factor

$$\text{Actual voltage Drop} = \alpha \times V_d \times \frac{\text{Actual load current}}{\text{Rated load current}} \times \frac{\text{Actual length of the line (m)}}{100m}$$

**α (Load Constant)** α = 1, concentrated load (a place such as an electrical room)  
 α = 0.5, Distributed load (a place such as a vertical section)

• F: Flanged End (panel connections)  
 • P: Plug-in Unit

Ampere(A)	Impedance(10 <sup>-3</sup> Ω /100m, 60Hz)			Voltage Drop(V/100m)				
	R	X	Z	0.7	0.8	0.9	1	
CU	1,000	7.10	16.24	17.02	28.7	26.72	23.33	12.30
	1,250	5.64	14.67	15.23	31.22	28.82	24.83	12.21
	1,600	3.95	12.22	12.55	31.84	29.07	24.61	10.95
	2,000	3.05	10.46	10.69	33.26	30.18	25.29	10.56
	2,500	2.36	8.79	8.97	34.36	31.03	25.80	10.23
	3,200	2.18	6.11	6.28	32.64	29.98	25.63	12.08
	3,600	1.92	5.64	5.78	33.48	30.66	26.08	11.94
	4,000	1.70	5.23	5.35	34.13	31.17	34.41	11.80
	5,000	1.33	4.40	4.49	35.25	32.06	26.96	11.51
6,000	0.91	4.27	4.31	38.28	34.17	27.84	9.46	

## NSPB-LV

LS C&S Busduct has been tested under actual short circuit conditions according to IEC 61439-1 and 6 [(previous standard) IEC 60439-1 and 2]

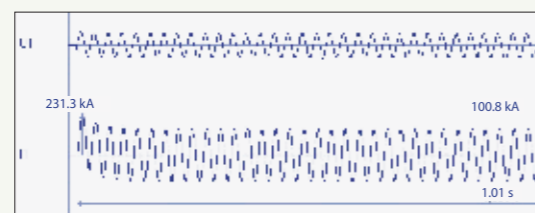

Ampere(A)	1,000	1,250	1,600	2,000	2,500	3,200	3,600	4,000	5,000	6,000
CU	1sec	40	40	50	50	50	50	80	80	100
	3sec	23	23	28	28	28	28	46	46	57

## Temperature Rise

The temperature rise limit is an important property which determines the performance of busducts. The temperature rise limit of the busduct is designed that when a busduct is operated with a rated current, the temperature limit values of the housing are within 55K as specified in IEC61439-1 and 6 [(previous standard) IEC 60439-1 and 2].

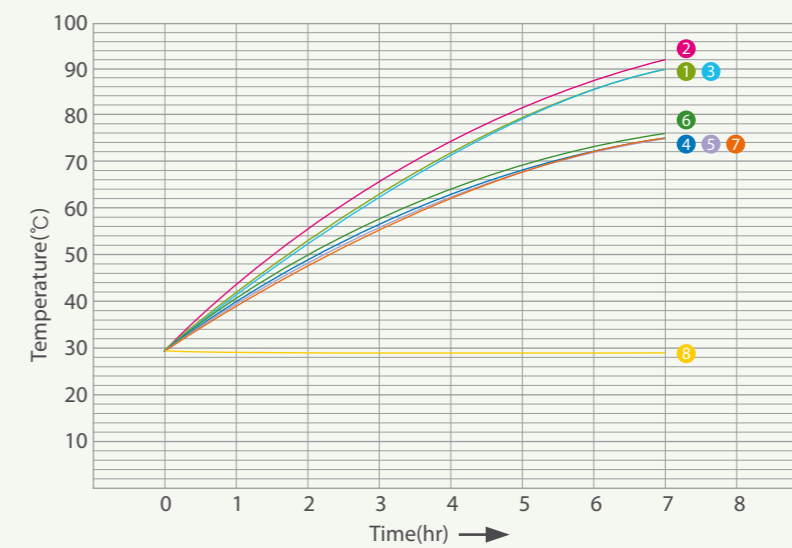
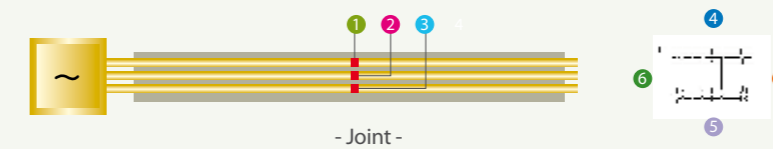
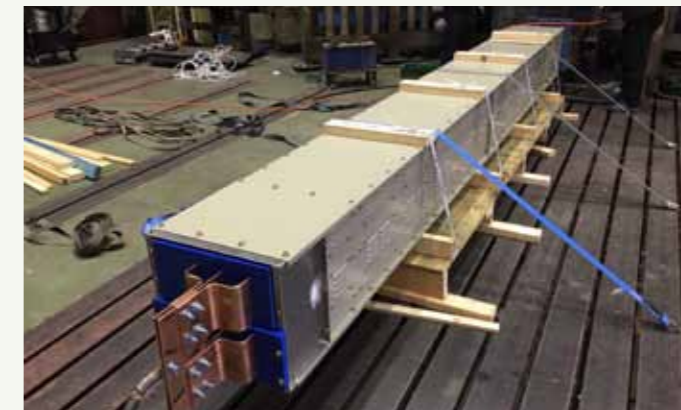

Classification	1	2	3	5	6	7	8	9
Sensor Location	Connection Conductor			Housing				Ambient Temperature
Temperature Rise Value	79.8	84.1	78.9	40.1	39.3	30	24.4	21.6

# MV Basic Structure

The NSPB-MV uses epoxy insulating material (thermal class 130 °C) to separate the phases, and secure them using high strength epoxy. It can be applied to 1000V or less, or between 800A and 4000A.

## Structure (Vertical)

- Al/ST/SPCC
- CU or AL

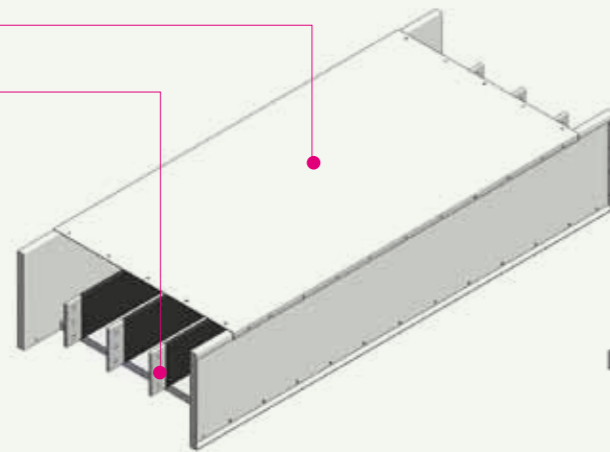

Sectional View

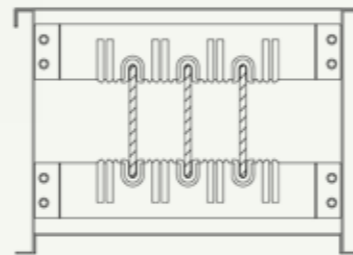

## Structure (Horizontal)

- Al/ST/SPCC
- CU or AL

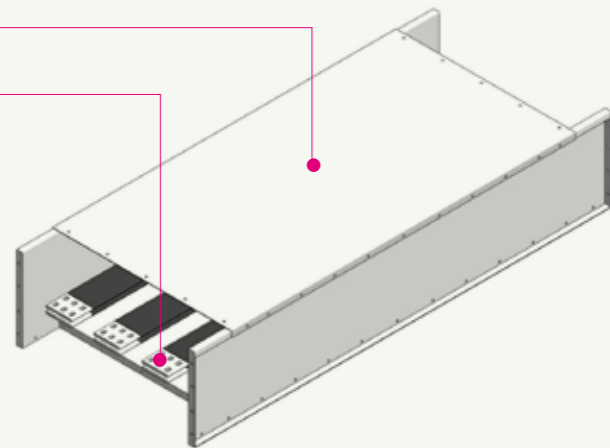

Sectional View

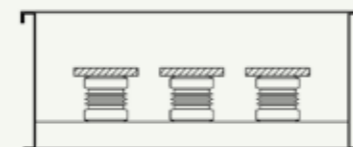

## Conductor insulation and Access

The conductors come with epoxy coating insulation. Tube insulation is also available on request. Use joint plates to connect the parts, and cover them with boots as shown in the image below.

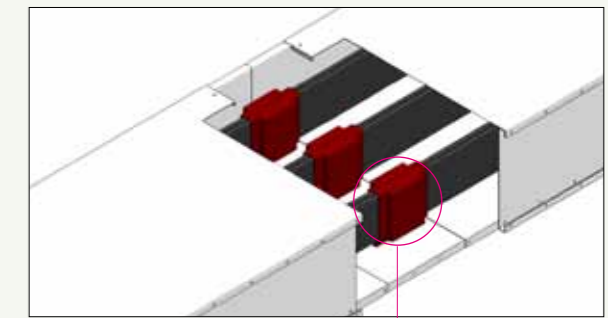
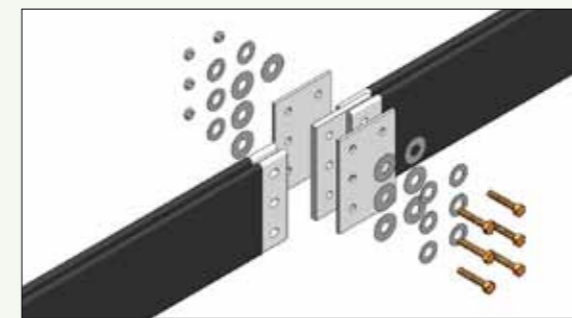

Boots

## Joint Covers

For indoor installation, applying joint covers are sufficient; however, for outdoor installation, final covers should be applied additionally on top of the joint covers. (Please contact our design team for further information.)

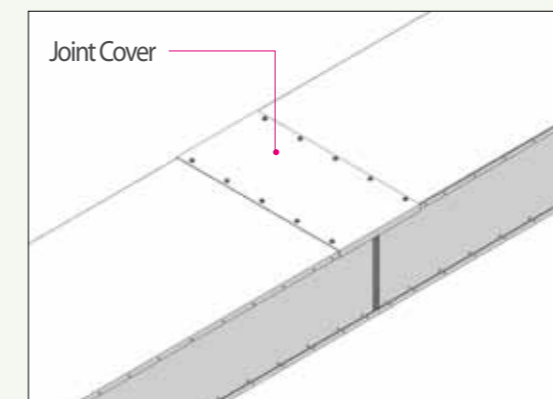

Indoor

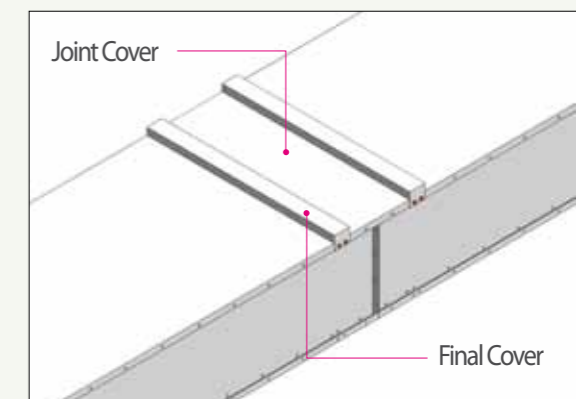

Outdoor

Final Cover

## Feeder (Alignment of the Conductors : Horizontal)

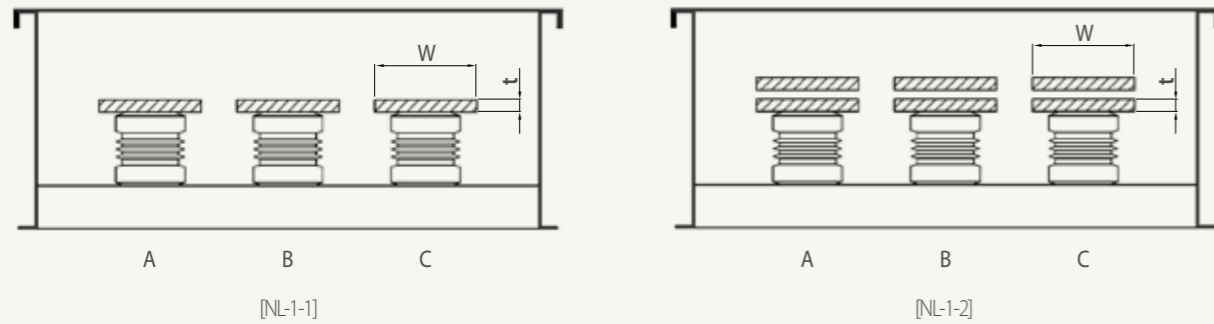

7.2kV~24kV (IEEE : 4.76~27kV)

Ampere(A)	Dimension (mm)		Fig.	
	t	W		
CU	630	6	40	NL-1-1
	800	6	50	
	1000	6	60	
	1250	10	50	
	1600	10	80	NL-1-2
	2000	10	100	
	2500	10	85	
	3200	13	100	
4000	15	125		

\* The standards of the conductors are only for reference, and they can be adjusted according to the installation environment, or on request. (For using aluminum conductors, please contact our design team for further information.)

\* The specification for over 5000A shall be designed and manufactured by a separate review

Note

### Skin Effect & Proximity Effect

Unlike DC system, due to the skin effect and proximity effect generated from the change in time of electromagnetic field of AC system, the resistance of conductors increase hence leading to the heating and the reduction of allowable current.

This phenomenon acts as the most important factor especially when designing the conductor size of large capacity products.

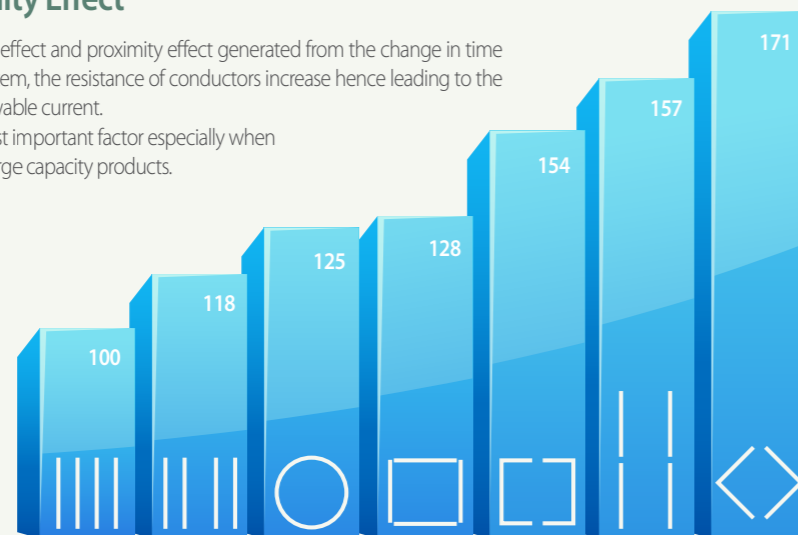

[Allowable current rate according to conductor shape and alignment (%)]

※ Source DIN 43670, 43671

## Feeder (Alignment of the Conductors : Vertical)

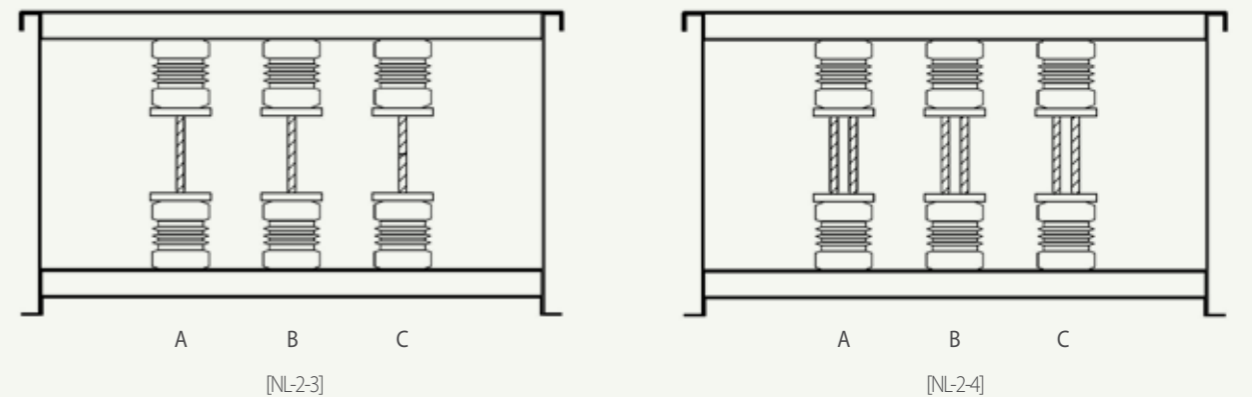
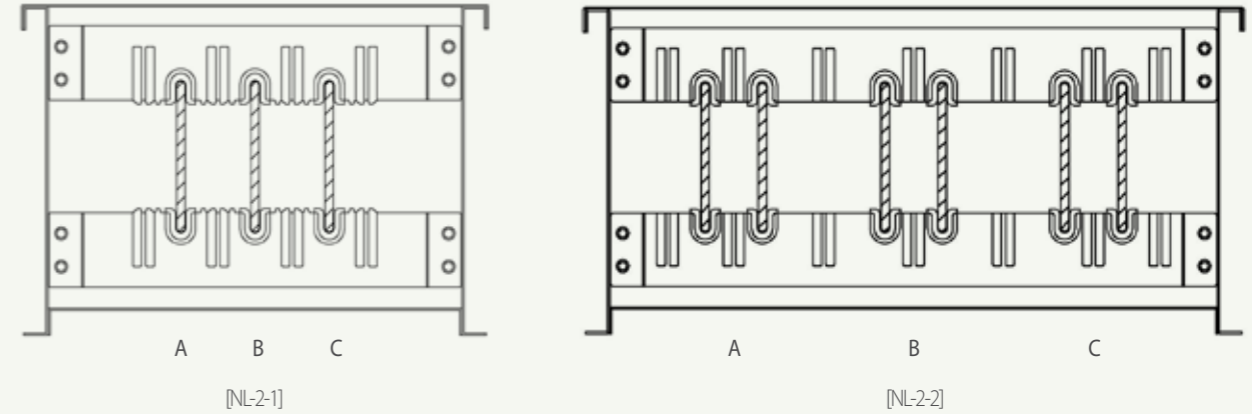

Note

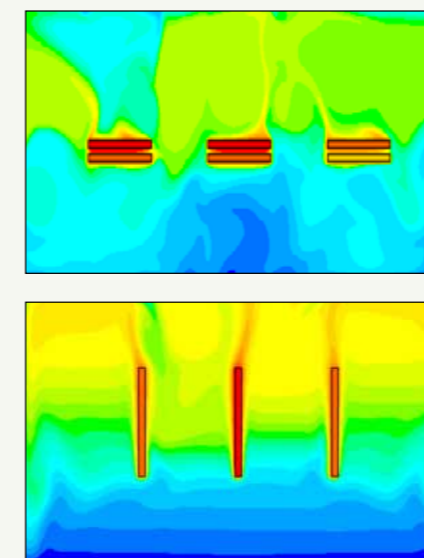

### Conductor Alignment/Size

Through product simulation and actual measuring experiment by heat emission mechanism of conductor, painting effect, external box material, grounding bar location etc, the optimized heating structure and conductor size shall be selected. (Vertical alignment of the conductor can reduce the conductor size than horizontal alignment.)



# Fittings

LS C&S NSPB has a wide range of fittings to satisfy any layout of buildings. Elbow angles other than ninety degrees are also available. Offsets or tees can be applied where the standard elbows are not feasible. (Please contact our design team for detailed information about the product size.)

## Elbow (Alignment of the Conductors : Vertical)

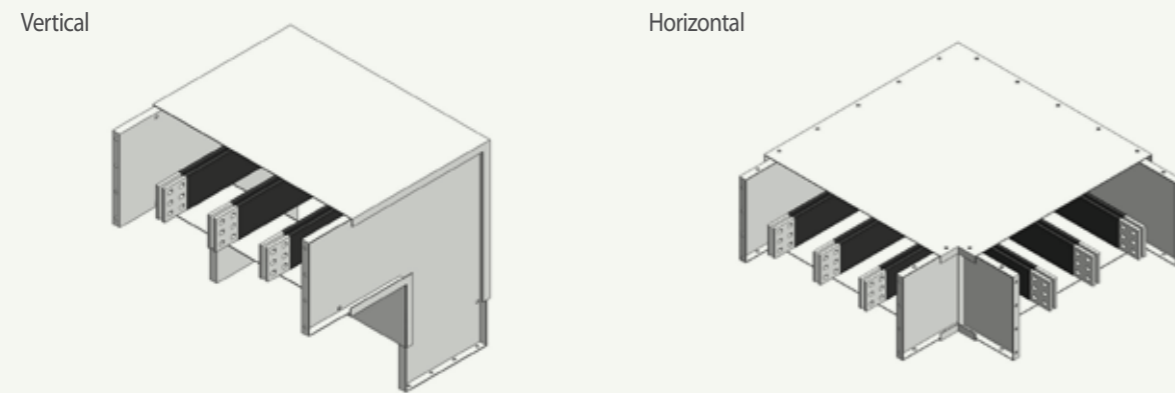

## Elbow (Alignment of the Conductors: Horizontal)

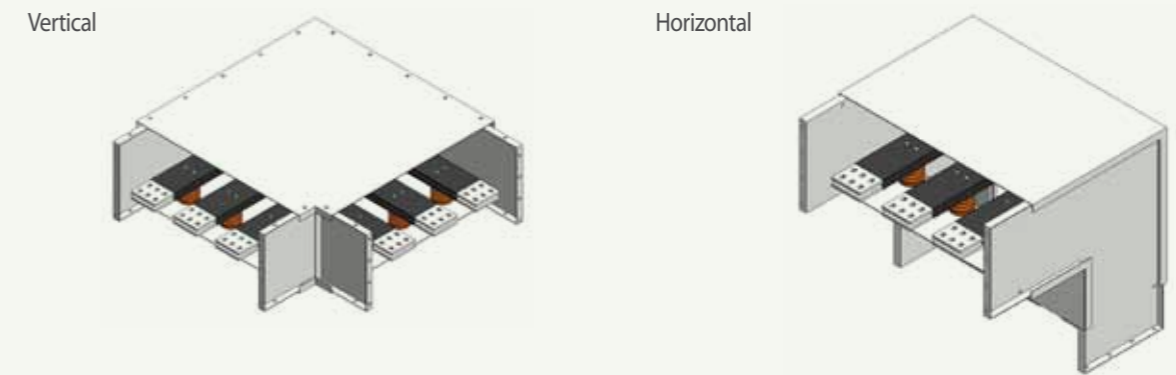

## Offset (Alignment of the Conductors : Vertical)

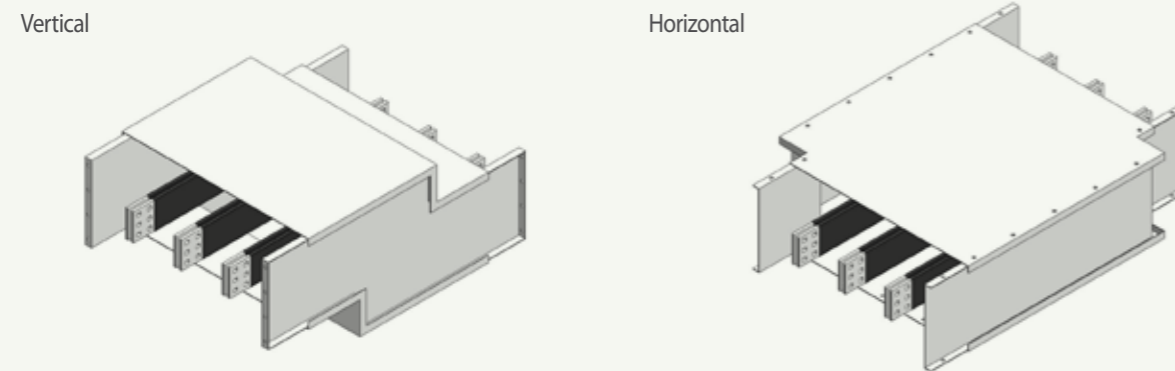

## Offset (Alignment of the Conductors : Horizontal)

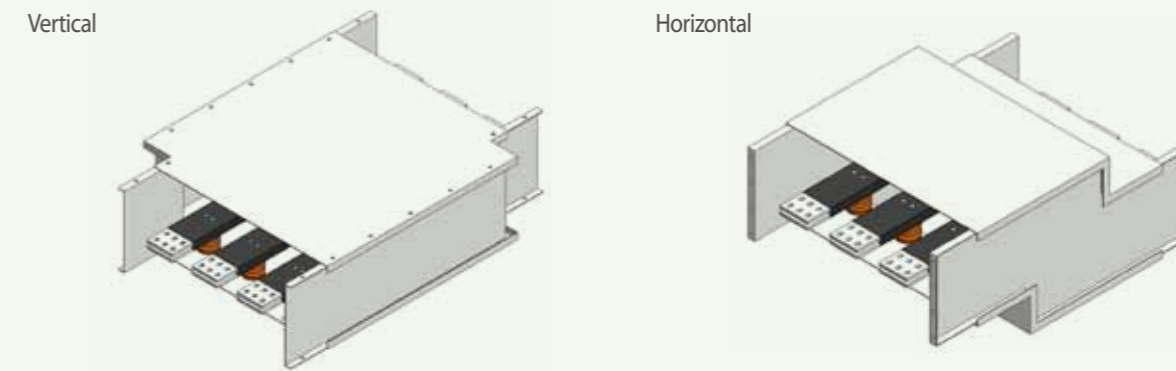

## Tee (Alignment of the Conductors : Vertical)

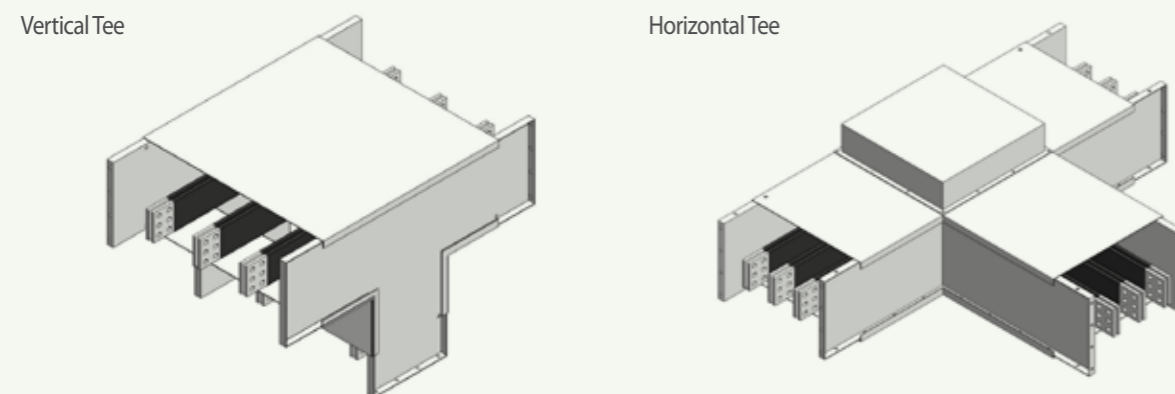

## Tee (Alignment of the Conductors : Horizontal)

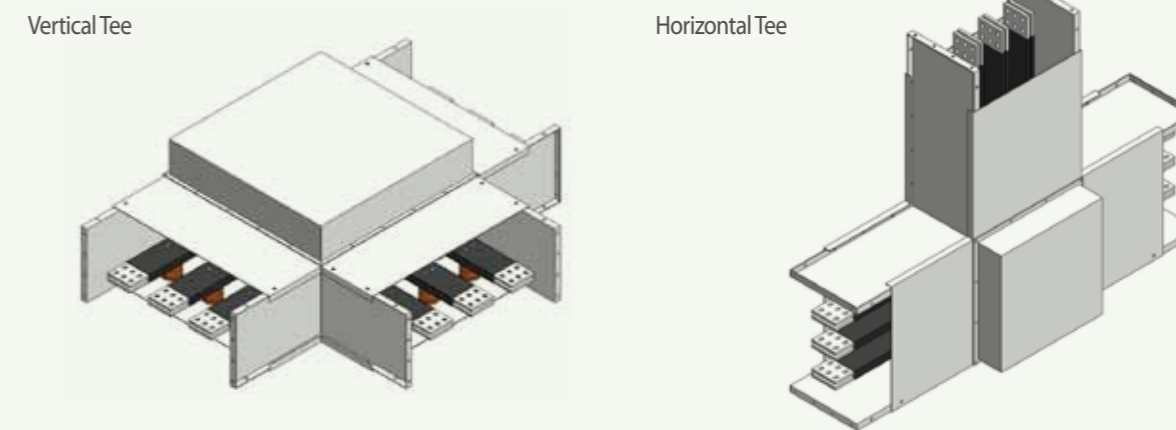

## Flanged End

The flanged end is used at a transformer or at a LV panel.  
(Please contact our design team for further information including the size and capacity.)

### Vertically Aligned Conductors

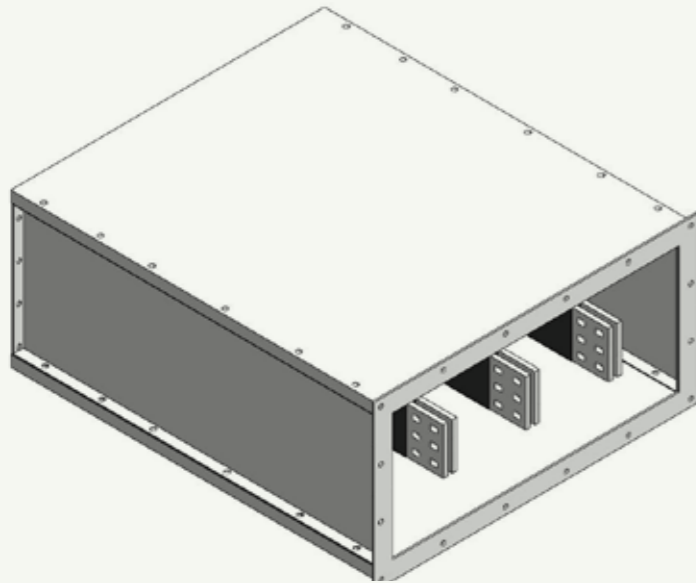

### Horizontally Aligned Conductors

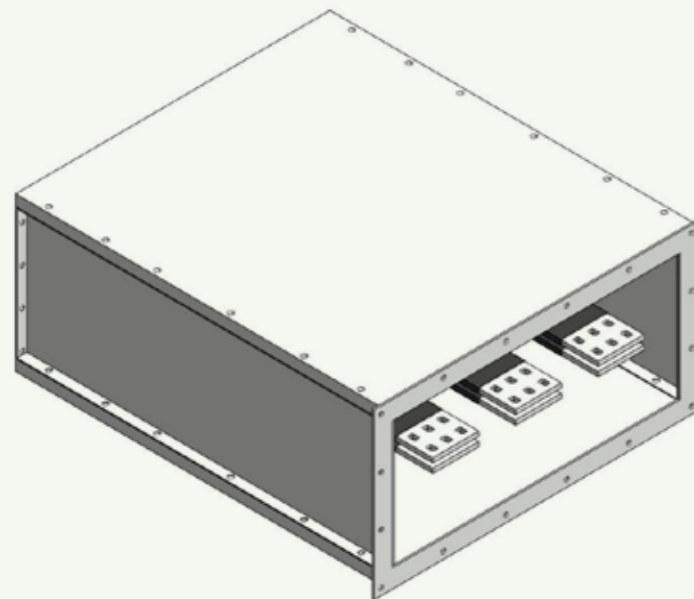

## Hanger

LS C&S NSPB can be installed using horizontal hangers, vertical hangers and wall brackets according to the installation environment. (Please contact our design team for detailed information about installation.)

### Horizontal Hangers

For horizontal installation, the NSPB requires two or more supports for each product.

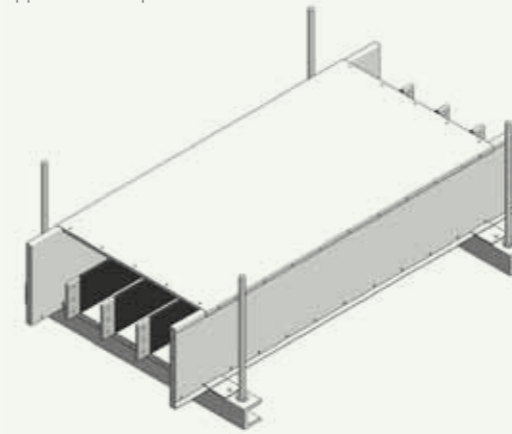

### Vertical Hangers

An additional reinforcement design provides stability for the vertical loading of the vertical feeders.

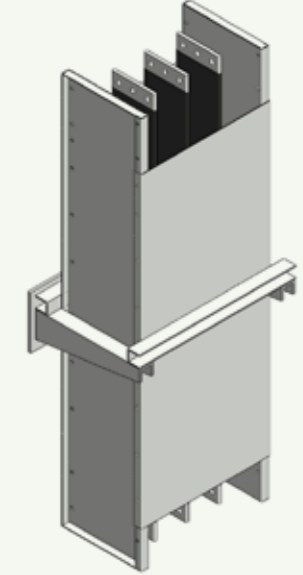

### Wall Bracket

Once the angles and the channels are applied on walls, they need to be fixed with bolts.

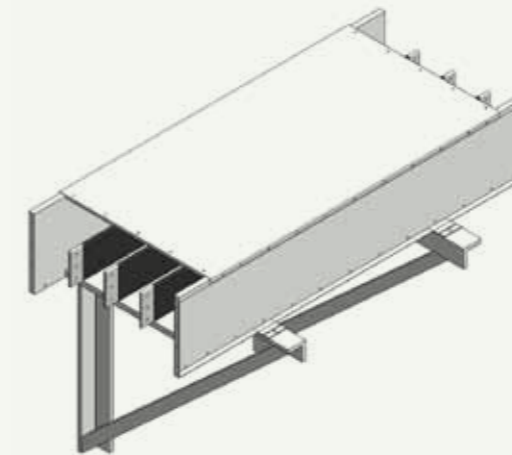

### Beam Support

It is supported on the post.

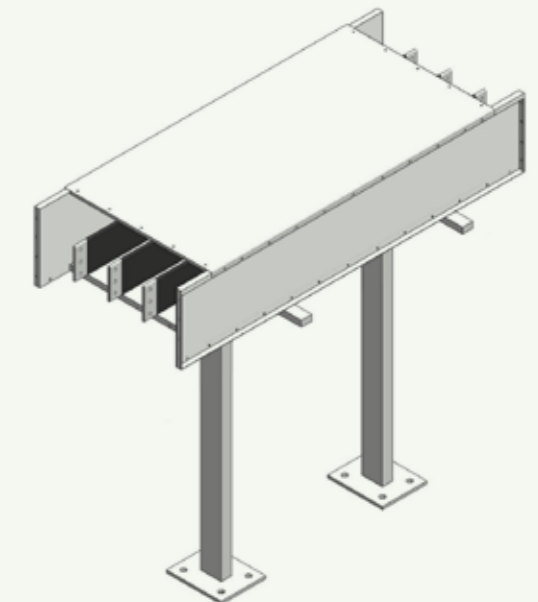

## The Joint of NSPB-MV

### STEP 1.

- The Busducts should be aligned at the top and the bottom and the left and the right as well as horizontally and vertically. Make sure that the surface is clear of dust before connecting them.
- Connect the Busducts by using joint plates and HT bolts as shown in the image. Tighten the bolts until the eye-marking is visible.
- Once they are connected, check for gaps between the bus bars and the joint plates using a feeler gauge.

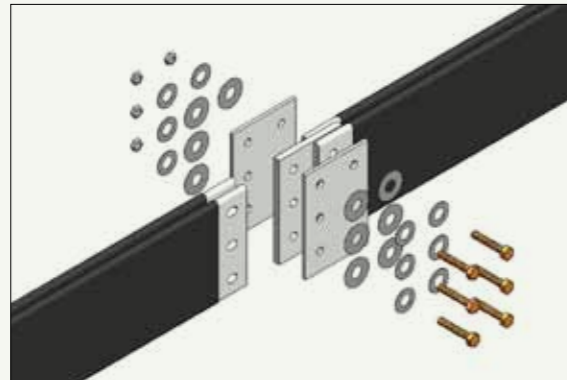

### STEP 2.

- For the NSPB-MV, apply boots additionally after joint plates have been connected as shown in the image.

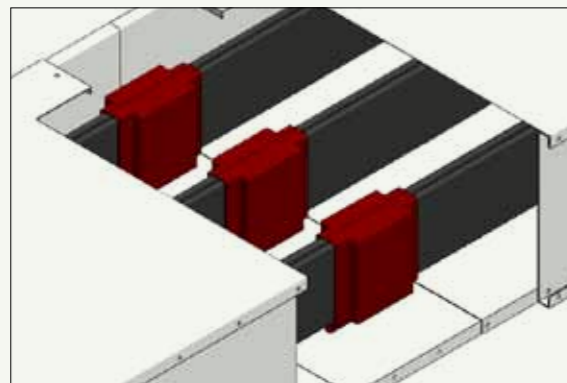

### STEP 3.

- For outdoor installation, apply the top and bottom joint cover and reinforcement covers. Apply silicone at both sides of the covers as shown in the image. (Torque = 120 kgf-cm)

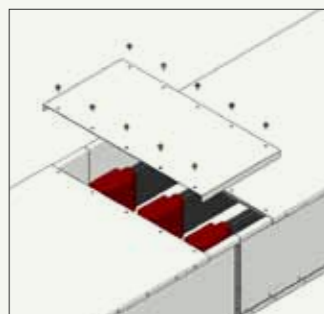

Indoor Type

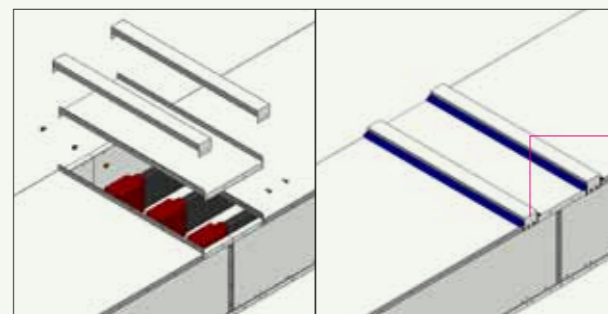

Outdoor Type

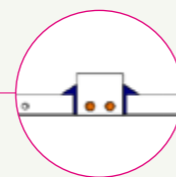

Silicone Application

## Technical Data

The short circuit strength of the LS C&S NSPB can be adjusted and produced in accordance with the request and specifics of the clients.

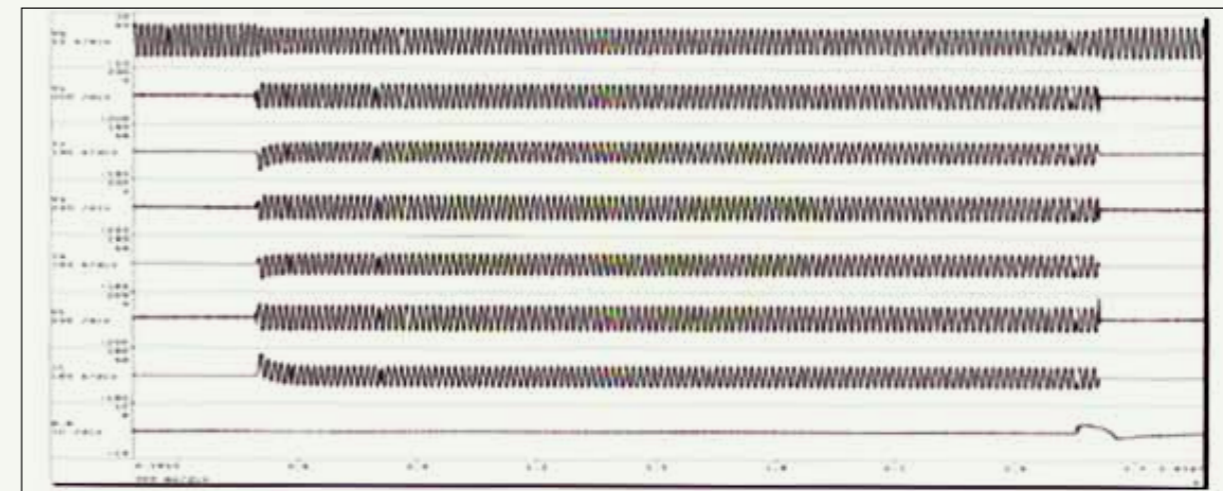
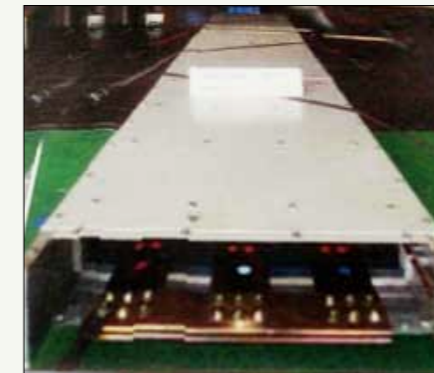

Rated Max. voltage (kV <sub>rms</sub> )	Short-circuit withstand current		Rated Max. voltage (kV <sub>rms</sub> )	Power frequency withstand voltage (kV <sub>rms</sub> ), 60Hz	Impulse withstand 1.2x50μs (kV <sub>peak</sub> )
	(kA <sub>rms</sub> ), 1sec.	(kA <sub>peak</sub> )			
7.2	40	104	0.635 and 4.76	20(19)	60
12	40	104	15	38(36)	95
24	25	65	27	50(60)	125

\* IEC(IEEE) standard

# Certification & Specification

## UL Certification



## KERI Certification



## ISO 9001



## ISO 14001



## OHSAS 18001



# Busduct Major References



Steel-making plant and sintering plant of Hyundai Steel Co., Ltd.

Investor : Samsung Engineering  
Construction Period : 2008



Korea Gas Corporation Substation 21 in Pyeongtaek

Investor : Korea Gas Corporation  
Construction Period : 2010



LG Chem Ltd. Yeosu Plant LDPE

Investor : LG Chem Ltd.  
Construction Period : 2011



JURONG AROMATIC COMPLEX

Investor : ABB Singapore  
Construction Period : 2012~2013



AKG2 (AL-KHALEEJ GAS) PROJECT PHASE II Onshore GAS Plant

Investor : Qatar  
Construction Period : 2007 ~ 2008



RAS LAFFAN PROJECT PHASE 6 & 7 Onshore LNG Plant

Investor : Qatar  
Construction Period : 2006 ~ 2007 Completed

# GLOBAL NETWORK

More than 60 Factories, Sales and Production Sites in 20 Countries.

- Factory
- Sales office
- Branch office

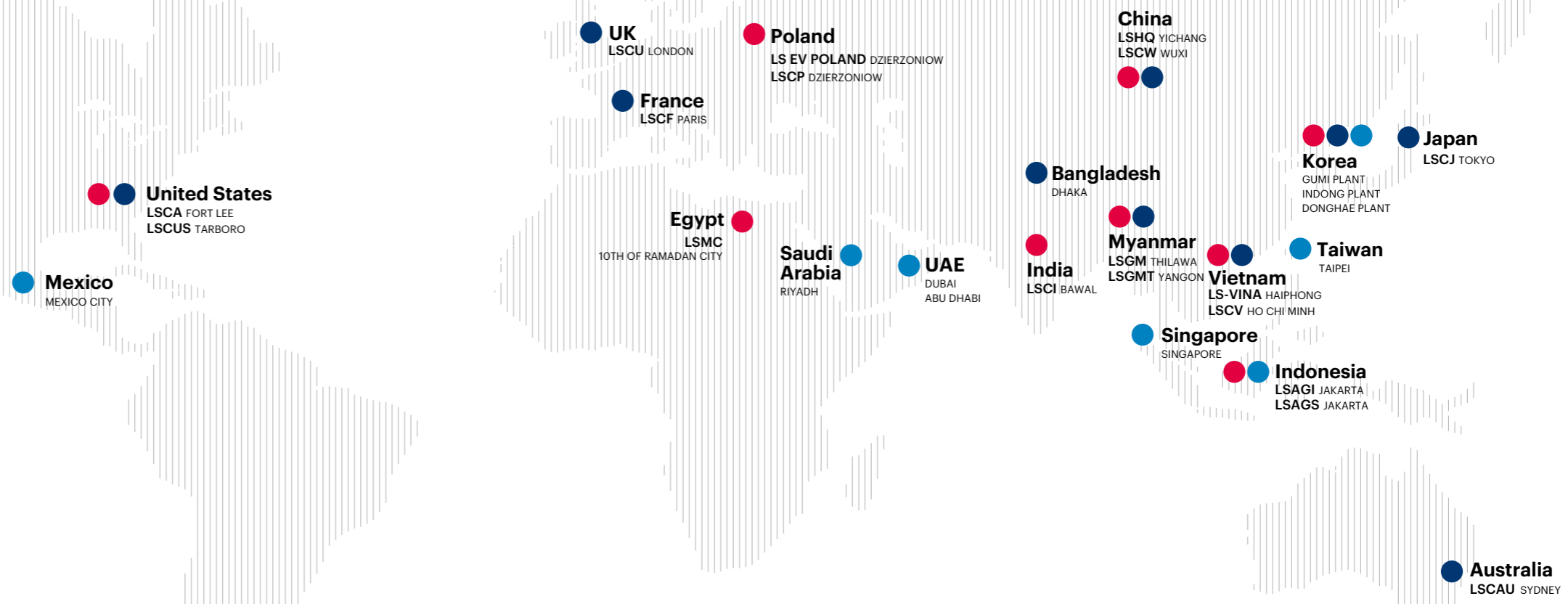

**KOREA**

**Gumi Plant**  
EHV / MV / LV cable  
UTP, Coaxial cable  
SCR, Magnet wire  
Overhead cable, Bus duct

**Indong Plant**  
Optical fiber  
Optical cable

**Donghae Plant**  
Submarine cable  
Industrial specialty cable

**CHINA**

**LSHQ(Yichang)**  
EHV / MV / LV cable  
Industrial specialty cable

**LSCW(Wuxi)**  
Industrial devices cable  
Automotive cable  
Harness & module  
Aluminum, Bus duct

**VIETNAM**

**LS-VINA(Haiphong)**  
EHV / MV / LV cable  
SCR, ACSR  
Overhead cable

**LSCV(HO Chi Minh)**  
MV / LV cable  
UTP, Optical cable  
Overhead cable

**INDIA**

**LSCI(Bawal)**  
EHV / MV / LV cable  
Coaxial cable  
Overhead cable

**USA**

**LSCUS(Tarboro)**  
MV / LV cable  
Control, Instrument cable

**POLAND**

**LS EV Poland./LSCP (Dzierzoniow)**  
Automotive battery components  
Optical cable



[www.lscns.com](http://www.lscns.com)  
Busduct System

18F, LS Yongsan Tower, 92 Hangang-daero, Yongsan-gu, Seoul, 04386, Korea  
Tel. 82-2-2189-8884 Fax. 82-2-6969-5424

©2020 LS Cable & System Ltd. All right reserved.

This product or document is protected by copyright and distributed under licenses restricting its use, copying, distribution, and recompilation. No part of this product or document may be reproduced in any form by any means without prior written authorization of LS Cable&System and its licensors, if any.

Products shown on this catalog are subject to change without any prior notice.