

DATA-WAY

Data Center Busway Solution



LS Cable & System

www.lscns.com
Data-way

18F, LS Yongsan Tower, 92 Hangang-daero, Yongsan-gu, Seoul, 04386, Korea
Tel. 82-2-2189-8884 Fax. 82-2-6969-5424

©2021 LS Cable & System Ltd. All right reserved.
This product or document is protected by copyright and distributed under licenses restricting its use, copying, distribution, and recompilation. No part of this product or document may be reproduced in any form by any means without prior written authorization of LS Cable&System and its licensors, if any.
Products shown on this catalog are subject to change without any prior notice.



LS C&S Busway Data-way

LS Cable & System's Data-way for Data Center meets various needs :
stable power supply, energy saving and recovery of investment cost.

It is a system that can satisfy your requirements and continuously respond to the changing distribution environment.

LS Cable & System's Data-way reduces time and cost loss incurred by cable extension and IT rack relocation.

Data-way is a solution to maximizing energy efficiency and stable power supply to your Data Center.

Why Busway in Data Center?

Summary

LS Cable & System Data-way is a new type of power distribution system that has several advantages compared to the existing cable distribution system.

Introduction

For the last 50 years, Data Centers used the cable power distribution system, as below.

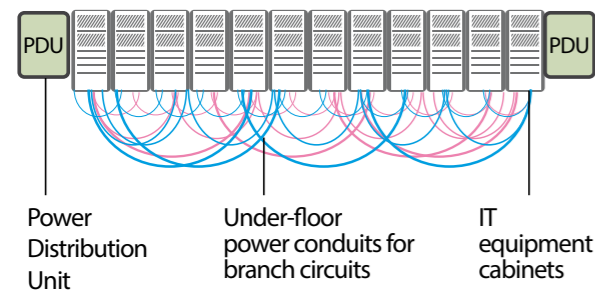

[Figure 1] Conventional Data Center power distribution system

The conventional power distribution system is configured through the Power Distribution Unit (PDU: 50kW to 500kW). The PDU contains a branch circuit and breaker corresponding to the number of racks (1.5kW to 15kW), and various modules for power monitoring. Each IT rack requires one or more power supplies, so cables are laid out as conduits or exposed through the floor of the server room as shown in [Figure 2].



[Figure 2]

Cable distribution system require frequent changes due to additional or replacment of IT Racks. This has led to the need for advanced Data Center's energy distribution system.

LS Cable and System's Data-way provides a convenient and efficient energy distribution system.

Background

Cable distribution system was an ideal choice when the number of IT racks were small, upgrades were uncommon and monitoring systems were not a necessity.

Data Centers are now facing situations that require upgrades from the existing cable power distribution system.

- ✓ The latest Data Centers require a large number of receptacles and hundreds of plug-in units that branch off.
- ✓ IT equipment in the IT Rack frequently needs to be updated and IT racks are constantly being relocated. Therefore, additional receptacles or power supply are constantly needed.
- ✓ As power needs increase, new source of power should be installed so that it does not interfere with the existing IT equipment.
- ✓ The power needed per IT rack is increasing dramatically, cabinets require several load branches,

The amount of power allocated per rack is increasing dramatically, often requiring a large number of load branches per cabinet, and the system, which is enclosed in the lower conduit of the server room, has a limited number of power supply circuits and is very difficult to respond to changes such as new power supply or power distribution.

Flaws of traditional cable distribution system

- ✓ Operator in the Data Center must remove and add the power supply system in the live state. (Risk Operations)
- ✓ Operator is unaware of which circuit is overloaded, and it is difficult to take action even if a disconnection occurs due to overload.
- ✓ Since the cooling ventilation system in the lower part of the server room is blocked by cables and conduit, it is difficult to maintain ventilation and optimum operational temperature for IT equipment.



[Figure 3] Cable distribution system in Data Center

Optimized power distribution system

- It must be safe to add or change new circuits while in use.
- There should be no cables in the bottom of the server room.
- The power of all circuits and the status of all breakers must be monitored from a distance.
- Additional IT equipment and power distribution equipment can be added easily.
- Receptacle in IT Rack can be replaced with ease.
- The main power line and emergency line can be monitored and managed.

The Data-way is a new method of power distribution systems that have been developed in accordance with the needs of Data Centers.



[Figure 4] Busduct distribution system 1

Why Busway in Data Center?

Decentralized distribution system.

Easy expansion with maximum flexibility.

Efficient energy usage.

Operational cost saving.

Flexibility

- Convenient upgrade and replacement of IT rack equipment.
- Applicable to all types of Data Center.

Monitoring System

- Data-way's power monitoring system allows real-time monitoring of power supply and efficiency.

Simple installation

- The extension and removal of the Data-way is as simple as fitting and removing socket-outlets.

Efficient space utilization

- Data-way takes up less space than cables.

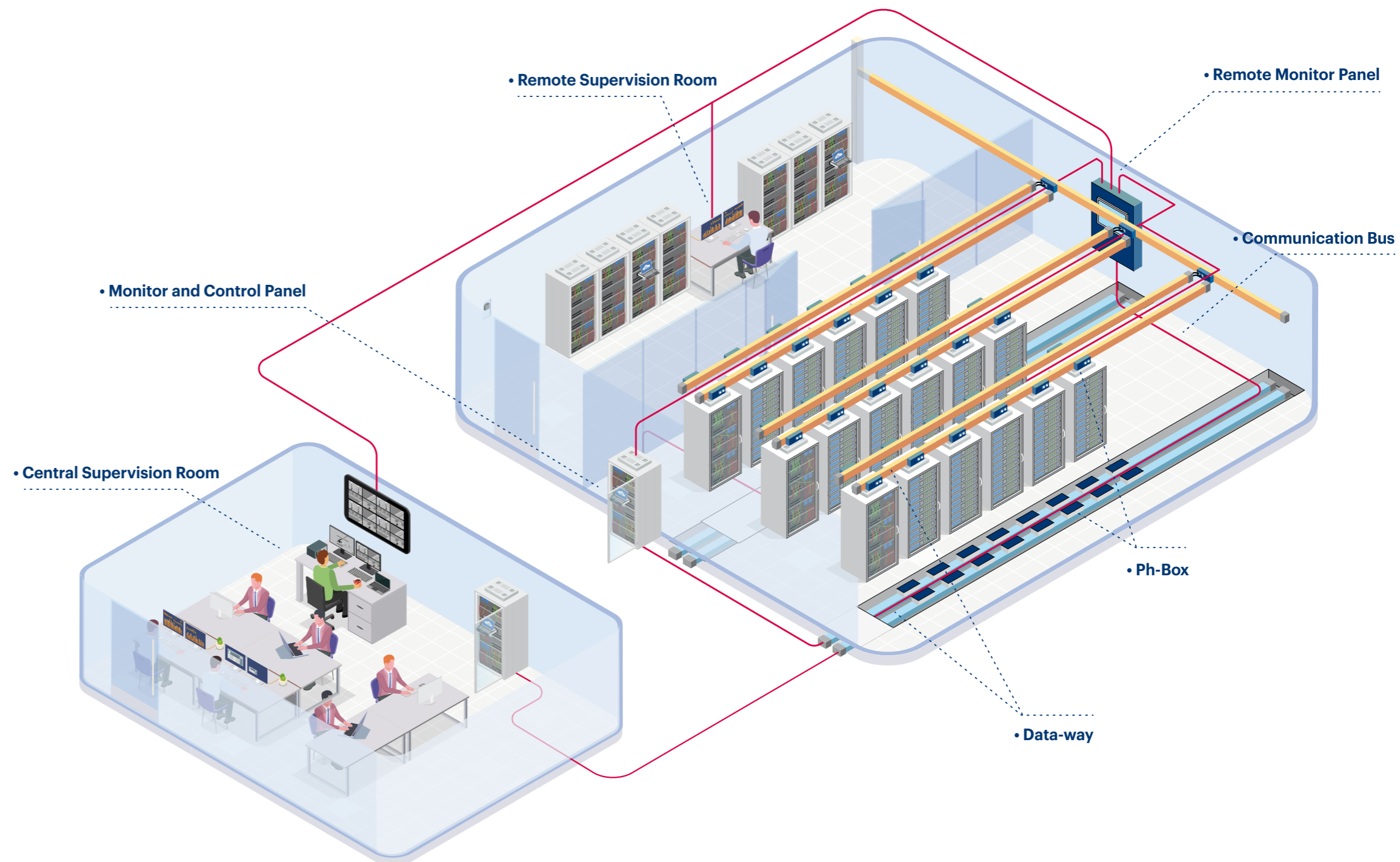

Why LS Cable and System Busway in Data Center?

- LS Cable and System provides solution to maximize customer satisfaction during project life cycle.
- A CS team is dedicated for post diagnosis and management.

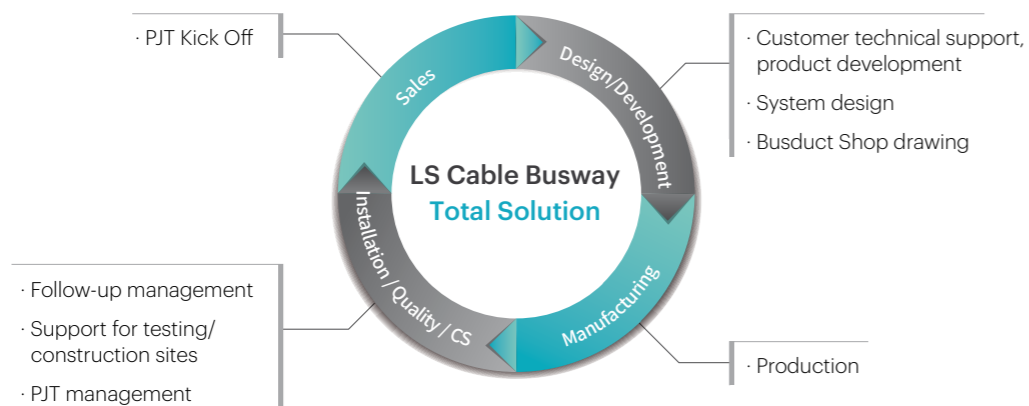

LS Cable and System Solutions for Data Center

Power distribution, metering and monitoring solution for Data Center.



Power Distribution Solution

- MV, LV Busway
- Data Busway, Ph-Box
- IT Rack MCCB



Power metering solutions

- Power Meter (i-way)
- IT Rack Meter (i-way)
- Server DCU



Power Monitoring Solutions

- Data HMI
- Touch Panel
- EMS, DCIM

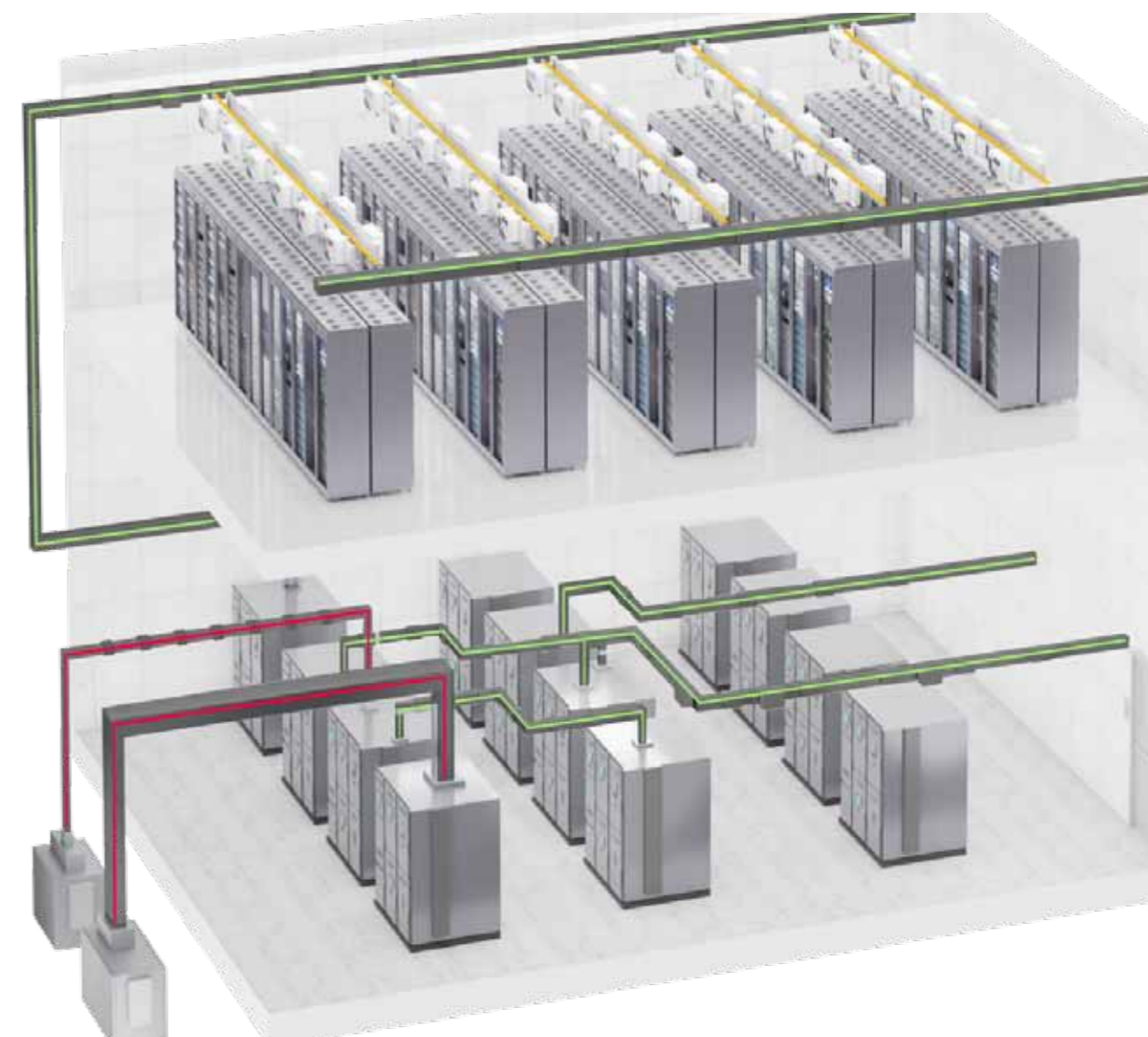

■ Data Center Busduct
 ■ LV Busduct
 ■ MV Busduct



· Data-way



· E-Series



· CR-way



· I-Series



· NSPB

Introduction

IT Rack receives power from two lines (50% of the maximum load per line) in case one line is down, the other line can supply the full load of power.

Application of Ph-Box varies according to the criteria below.

- Number of feeders.
- Feeder capacity.
- Need for residual current protection.
- Whether monitoring function is required.



LS Cable Product Solutions for Data Center

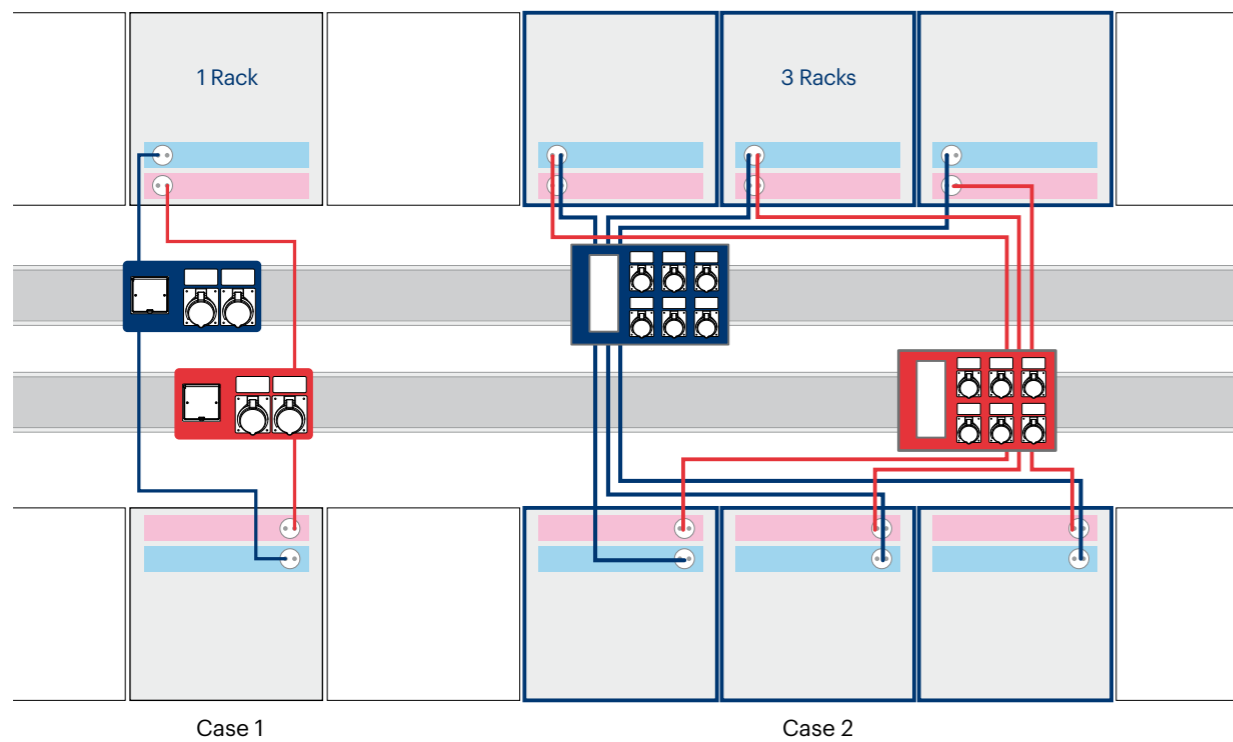

Data Center Distributed System

IT Rack Power Distribution #1

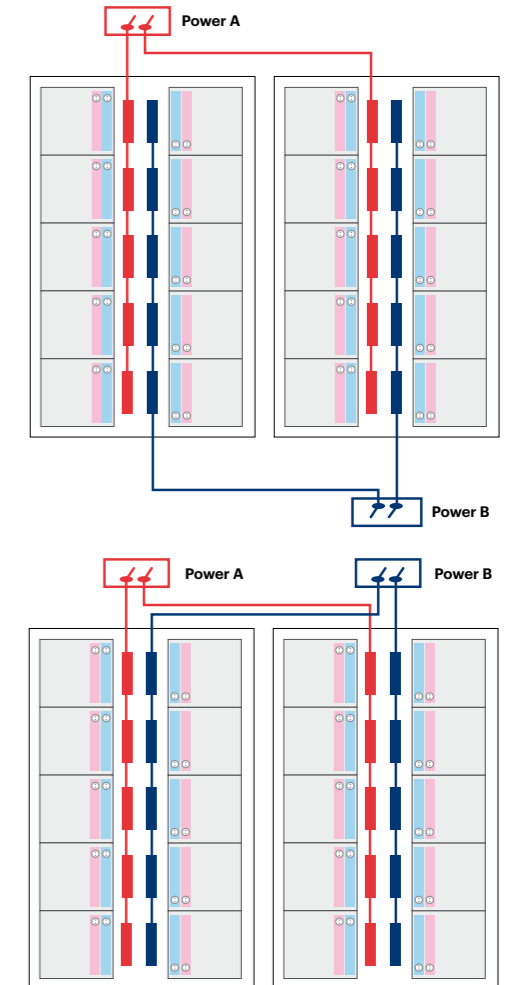
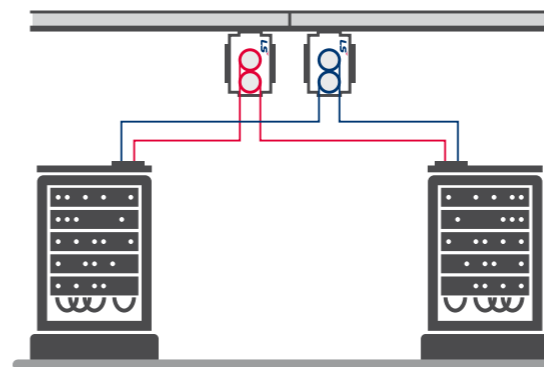

IT Rack Power Distribution #2

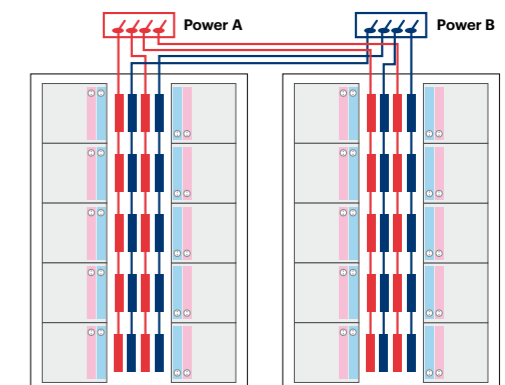
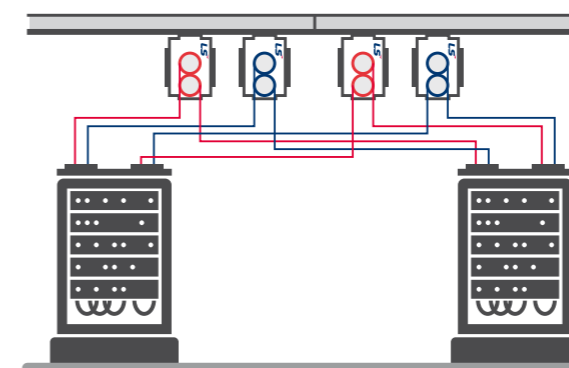

Data Center Distributed System

Above IT Rack Installation

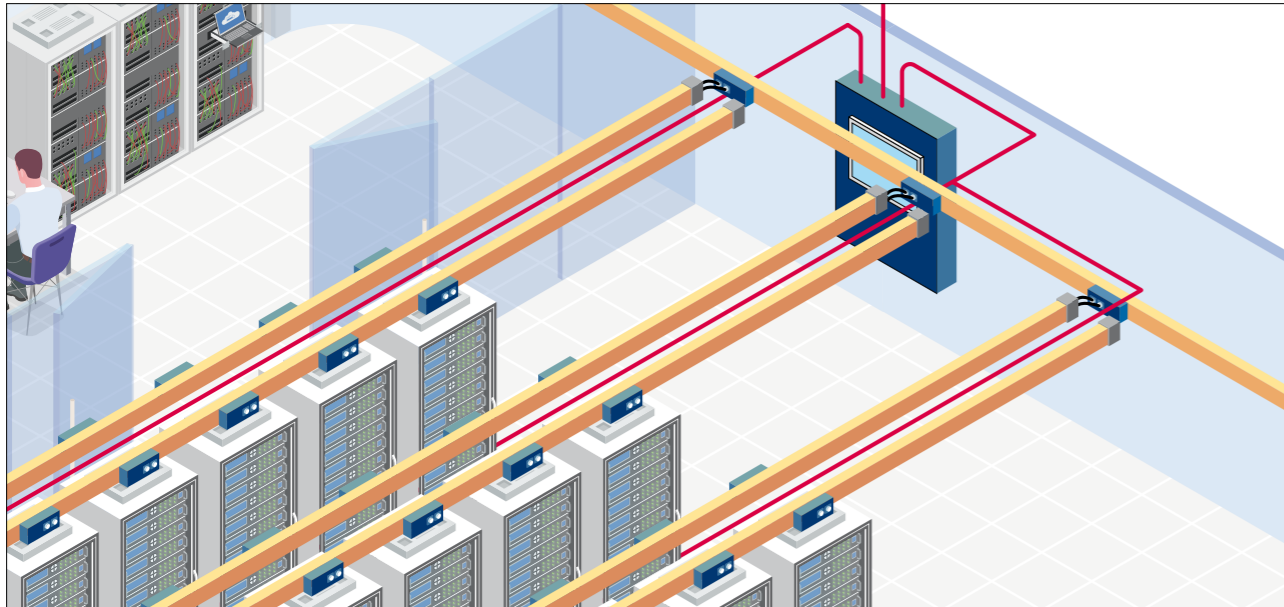

Under IT Rack Installation

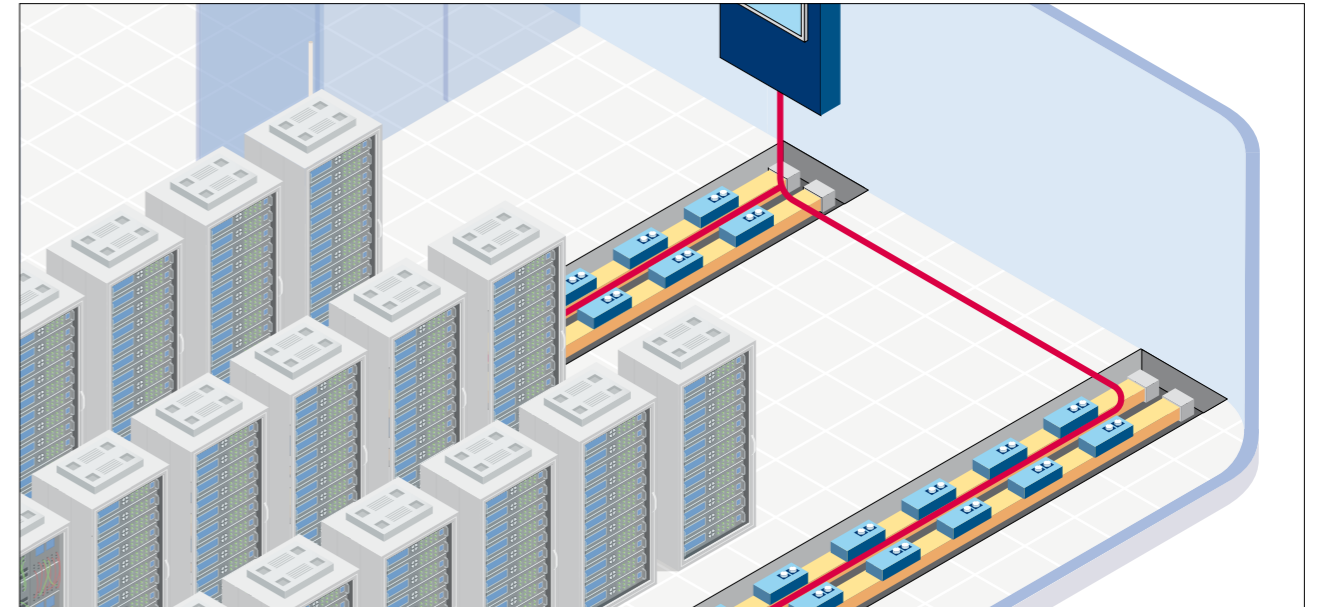

When installed on the false floor, Data-way can be installed in the walkway between two lines of IT Rack.

Examples

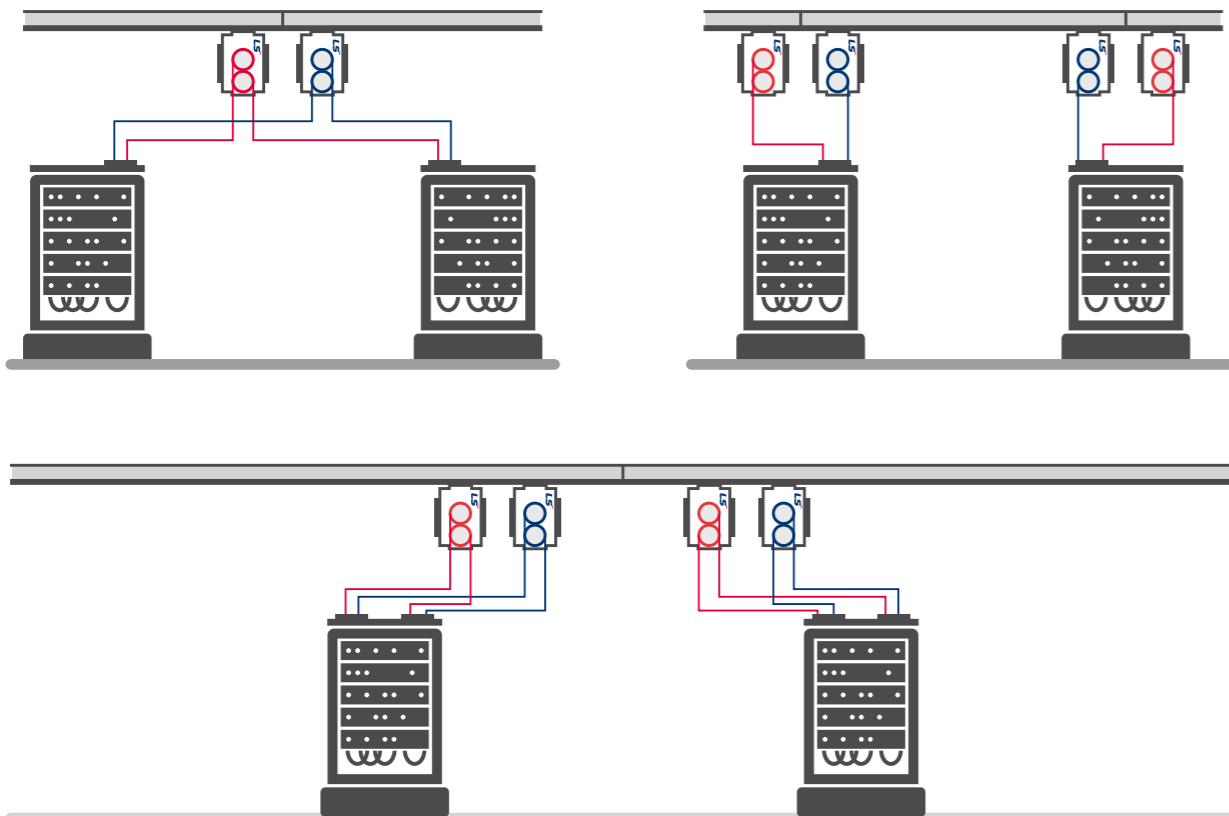

Examples

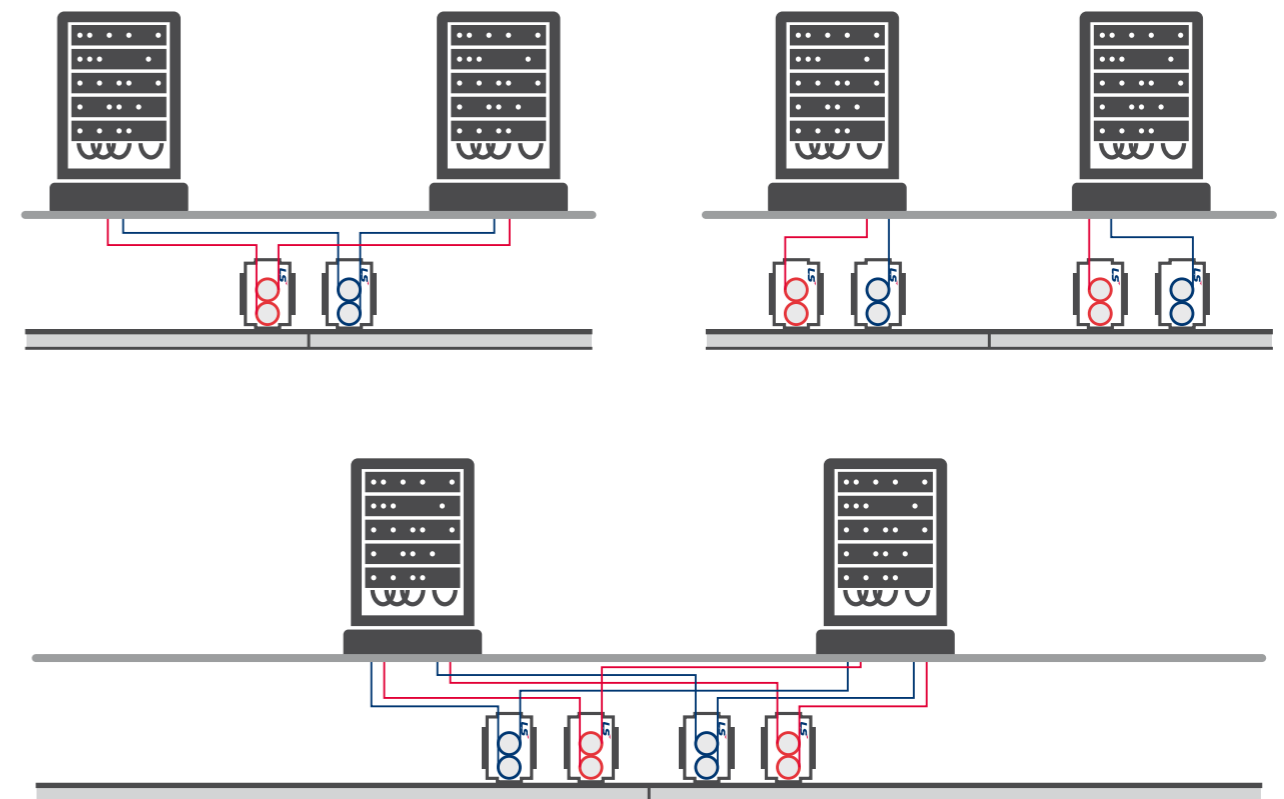

Monitoring

Overview

Smart-*i* collects the following data for each IT Rack and stores it in the DCU :
Power consumption, power current, power rate, voltage, power rate, and total harmonics (THD) and MCCB status.

Data is collected by the i-Meter in the Ph-Box and transferred to Modbus/TCP protocol.

This information is transmitted to the DCU via CAN protocol. The server must be protected by a circuit breaker and measure voltage, current, power cos φ and THD. These data are sent from the i-meter to the server PC via the DCU through the Modbus protocol.

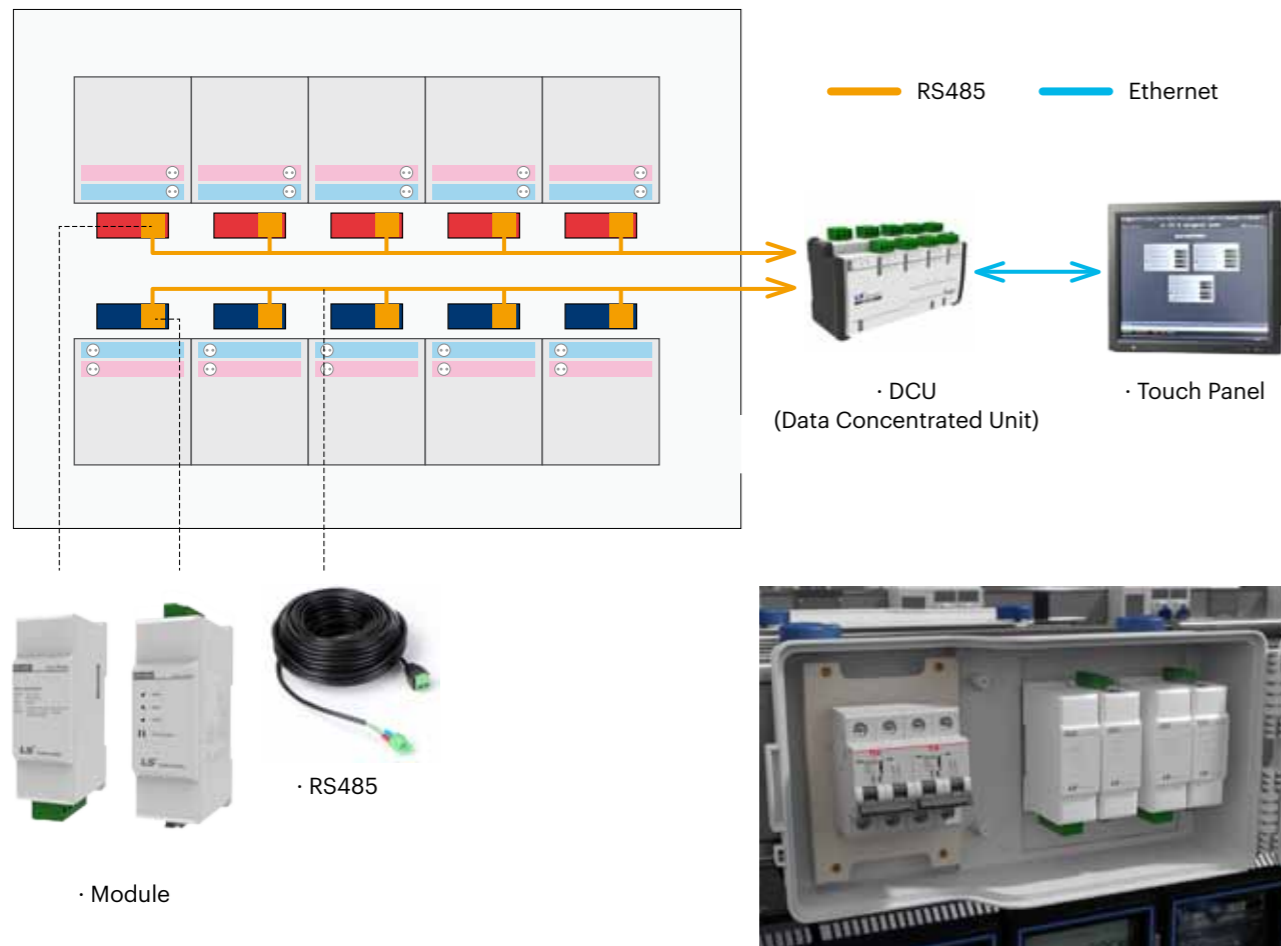

The status for each IT Rack is stored in the Ph-Box metering module.
The measured data in the metering module is transferred and stored in the DCU.
Diverse monitoring system is available depending on the type of Data Centers.

Smart-*i*



· Power Module



· Metering Module



· Comm. Module



· Data Concentrated Unit

Display Panel



Capable of handling 100,000 points of I/O data.
Communicate and monitor hundreds of modules simultaneously.
Communication protocol : MODBUS, Zigbee, BACnet, PLC

Information is displayed using graphical EDIT module.



Through HMI configuration, the operation program maintains user-friendly functions.

* HMI : Human Machine Interface.

Monitoring

Monitoring Screen



Monitoring software developed for Smart-*i* for Data Center provides status such as power consumption, circuit breaker status, lack of individual consumption, and proactive alerts for Smart-*i* Server Room IT Rack in real time.



· Main Screen



· MCCB/ Power Distribution Monitoring

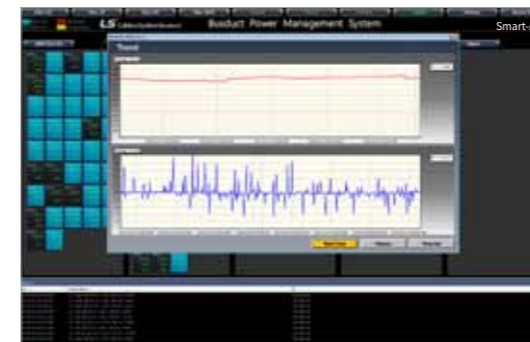

· Trend Monitoring

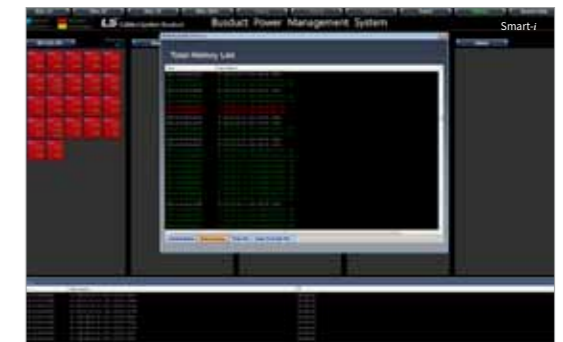

· Alarm Records



· Main Screen



· Power Distribution Monitoring



· Trend Monitoring



· Alarm Records



· Main monitoring screen



· Rack monitoring screen

Monitoring is available for each line and the complete area. Power conditions, including current, voltage and THD can be view in one screen.

- Detail information for each feeder
- Voltage
- Current
- Leakage current
- Power
- Demand
- Temperature
- Sag/Swell
- Breaker on/off status
- Power consumption
- Power factor
- Frequency
- THD

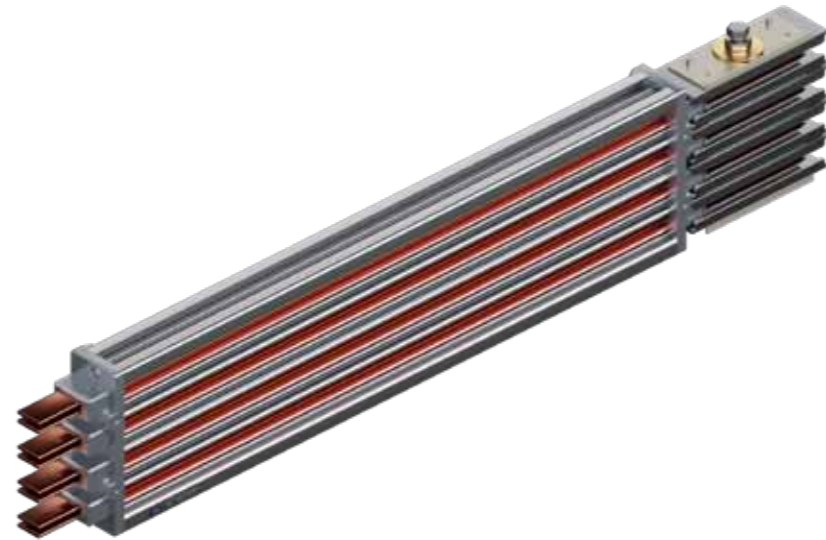



General Data	19
Smart-i-Ph-Box	22
Installation	28
BPMS	30
Certification	34
The Sales References	35
Global Network	36



Data-way is designed to satisfy the features required for Data Center up to AC 1000V / 800A

- 

High Current Density
The busduct has a compact design compared to the existing models by using an effective heat-radiating housing profile and can carry from 160A up to 800A with reduced loss of electric power.
- 

Permissible Operating Temperature
The cross sectional areas of the conductor and housing profile are designed to meet the standard permissible operating temperature of IEC 61439-1, 6 or UL 857. Therefore the temperature rise limit of the housing is within 55K or less of the ambient temperature.
- 

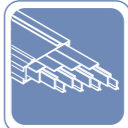
Eco- Friendly
Data-way acquired RoHS certification. Only using components without hazardous substances such as lead, cadmium, mercury and chrome.
- 

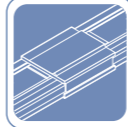
Conductors
Data-way uses either copper conductors with conductivity over 99%, or aluminum conductors with conductivity over 61%. U shape of conductor enables the Data-way to achieve the best performance and easy distribution.
- 

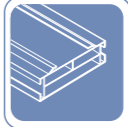
Connection
• Kit : DH (dual head) bolts and Visible-label (Redtag)
Check for installation using the contact
- 

Housing / Distribution
Data-way uses an effective heat-radiating aluminum housing which produces an excellent mechanical strength and heat radiation. It provides two distribution solution of Track type / Plug In type.

General Data

Feeder



Conductor	Ampere	Size (mm)		Weight(kg/m)
		H	W	
AL	160	52	150	7
	250	52	150	7
	400	67	150	9
	630	87	150	12
CU	160	52	150	10
	250	52	150	10
	400	52	150	11
	630	67	150	15
	800	87	150	21

* For more than 1000A, please contact our ENG team.

Plug in Feeder



· Plug-in type

· Track type

Conductor	Rating (A)	Length (mm)	Number of Plug in Hole		Weight (kg/m)	Notes
			Open-channel	Plug in Hole		
AL	160A	3000	-	6	7	
	250A		-		7	
	400A		-		9	
	630A		-		12	
CU	160A		-		10	
	250A		-		10	
	400A		-		11	
	630A		-		15	
	800A	-	21			

Feed in Unit

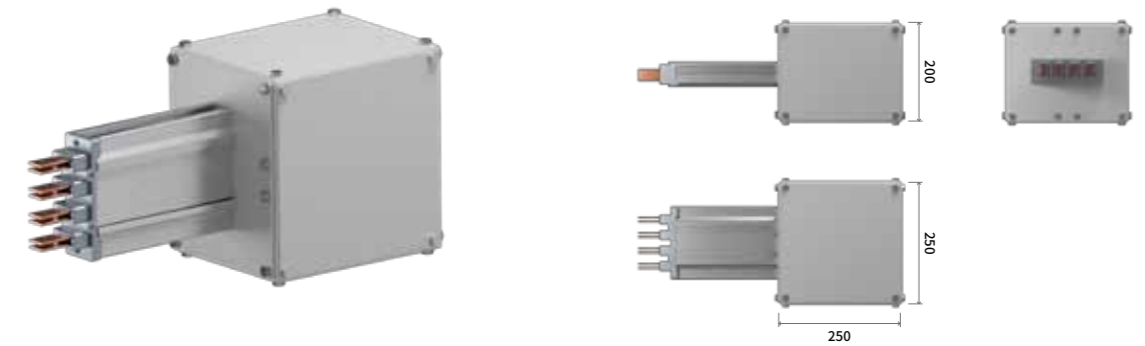

Conductor	Rating (A)	Mounting	Connection	Size (W x H x D)	Weight (kg/m)
AL	160A	Hanging	Terminals	250 x 250 x 200	9
	250A				9
	400A				10
	630A				11
CU	160A				10
	250A				10
	400A				11
	630A				13
	800A	16			

Technical Data

• Impedance / voltage drop

Ampere	10 ⁻² Ω /100m, 60Hz			V _s potential drop(V/100m)				
	R	X	Z	0.7	0.8	0.9	1.0	
AL	160	18.99	7.35	20.36	4.29	4.62	4.94	5.26
	250	18.99	7.35	20.36	6.71	7.21	7.72	8.22
	400	11.98	5.92	13.36	7.04	7.46	7.88	8.30
	630	8.11	4.75	9.40	7.75	8.12	8.48	8.85
CU	160	13.98	7.42	15.83	3.33	3.51	3.69	3.87
	250	13.98	7.42	15.83	5.20	5.48	5.77	6.05
	400	11.70	7.35	13.82	7.20	7.50	7.81	8.11
	630	7.46	5.92	9.52	7.63	7.80	7.97	8.14
	800	5.11	4.75	6.98	6.93	6.98	7.03	7.08

• Short circuit strength

Ampere	AL(kA)	CU(kA)
	1 sec.	1 sec.
160	15	20
250	15	20
400	15	20
630	15	20
800	-	20

Smart-i-Ph-Box

Features



Smart-i-Ph-Box #1

- Reinforced plastic enclosure
- Up to 63A
- Up to two receptacles available.



Smart-i-Ph-Box #2

- Metal enclosure
- Up to 63A
- Up to three receptacles available.



Smart-i-Ph-Box #3

- Metal enclosure
- Up to 63A
- Up to six receptacles can be available.



Features

The LS Cable and System Data-way Ph-Box consists of:



· Circuit protection breaker

Protects the facility/device from over-current, short-circuit currents from 1 to 63A.

MCCB with high capacity is available for special facility/device.

Internal accessories such as AX, AL, SHT, and UVT allow remote check of breaker on, off, and fault conditions.



· Current Transformer

Current metering available from 16 to 800 A.

- General : 63 to 800A

- Split type: 16 to 125A

The split type can be replaced while in use.

· Smart-i

Smart-i provides real-time information about power usage. Power usage information is sent through the selected metering module according to the single-phase and three-phase method. The default configuration is power module + metering module + communication module. Additional functions/ can be added depending on needs. The voltage used is available in a wide range from AC/DC 80 to 520V.



· DCU (Data Concentrator)

Collects, stores, and sends information from each meter to the higher device. Reliable communication is required for sending information from a large number of racks. It must also be able to process information from multiple meters. Capable of processing 128-Node simultaneously.



Smart-*i*-Ph-Box

16 to 63A Smart-*i*-Ph-Box



· Front

Ph-Box_P001

Pole	Rating (A)	Feeder	Sockets	Direction	Metering	Size (WxHxD)	Weight(kg)	Notes
2	16A	1, 2, 3	Y/N	Front / Side	Y/N	Front 340x190x190	4	
	32A	1, 2, 3					4.5	
	63A	1, 2, 3					5	
4	16A	1	Y/N	Front / Side	Y/N	Side 340x190x190	4	
	32A	1					4.5	
	63A	1					5	

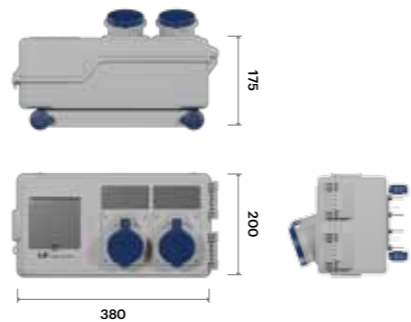

· Front

63 to 125A Smart-*i*-Ph-Box



· Front

Ph-Box_M003

Pole	Rating (A)	Feeder	Sockets	Direction	Metering	Size (WxHxD)	Weight(kg)	Notes
2	16A	1, 2	Y/N	Front / Side	Y/N	Front 450x190x160	6	
	32A	1, 2					6.5	
	63A	1, 2					7	
4	16A	1	Y/N	Front / Side	Y/N	Side 450x190x140	6.5	
	32A	1					7	
	63A	1					7.5	



· Side

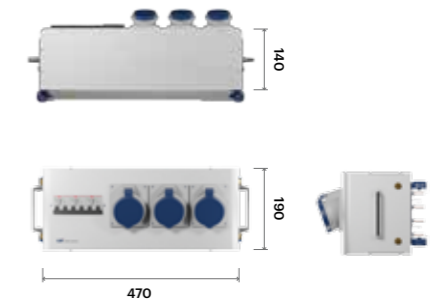

· Front



· Front

Ph-Box_M002

Pole	Rating (A)	Feeder	Sockets	Direction	Metering	Size (WxHxD)	Weight(kg)	Notes
2	16A	1, 2	Y/N	Front / Side	Y/N	Front 320x190x160	5	
	32A	1, 2					5.5	
	63A	1, 2					6	
4	16A	1	Y/N	Front / Side	Y/N	Side 320x190x140	5.5	
	32A	1					6	
	63A	1					6.5	

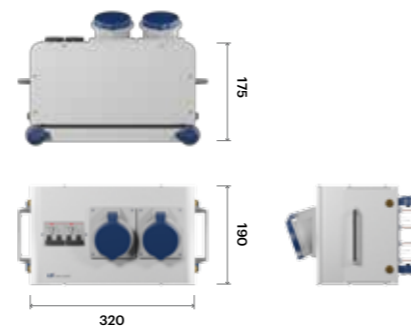

· Front



· Side



· Front

Ph-Box_M006

Pole	Rating (A)	Feeder	Sockets	Direction	Metering	Size (WxHxD)	Weight(kg)	Notes
2	16A	1, 2	Y/N	Front / Side	Y/N	Front 580x190x290	9	
	32A	1, 2					10	
	63A	1, 2					11	
4	16A	1	Y/N	Front / Side	Y/N	Side 580x190x140	10	
	32A	1					11	
	63A	1					12	



· Side

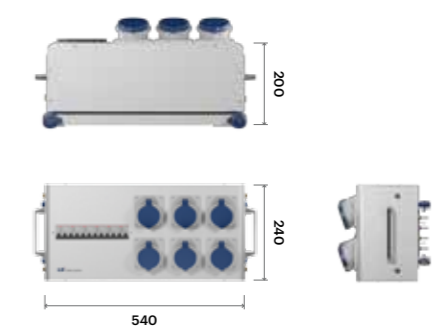

· Front

Smart-i-Ph-Box

Smart-i-Ph-Box #1

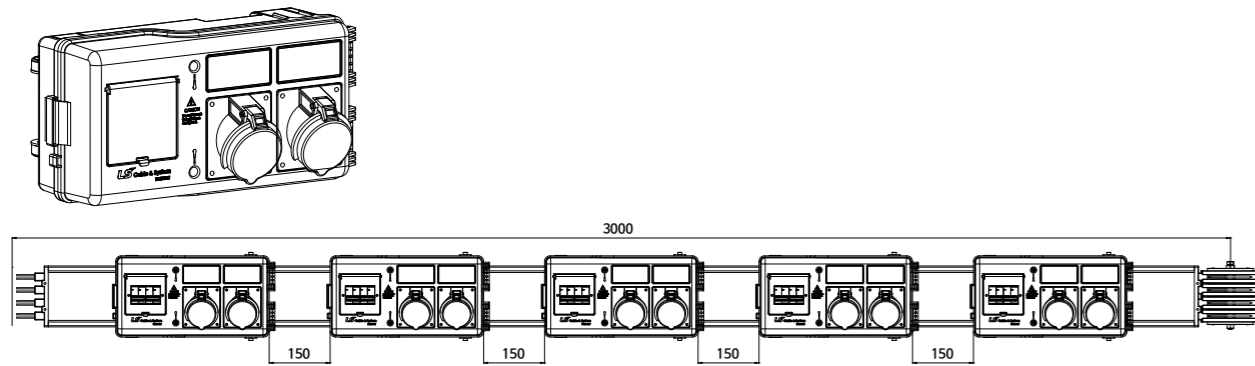

Smart-i-Ph-Box #2

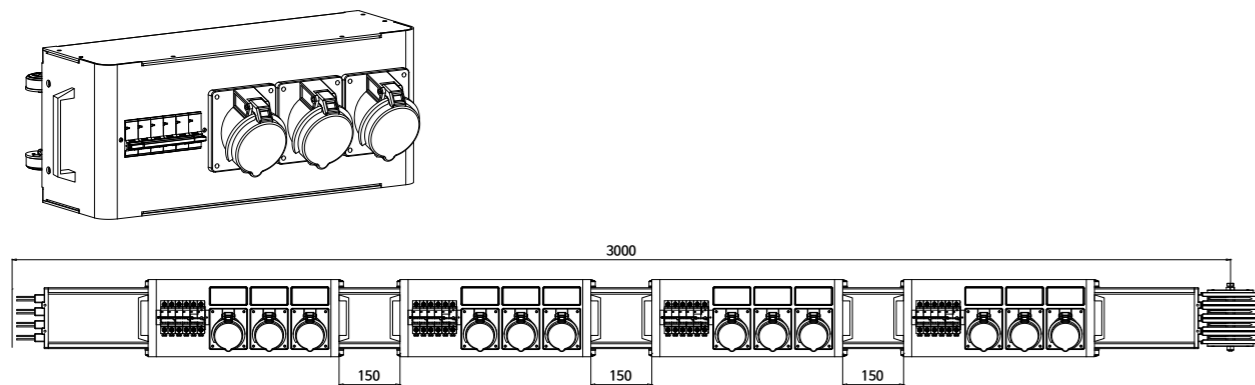

Smart-i-Ph-Box #3

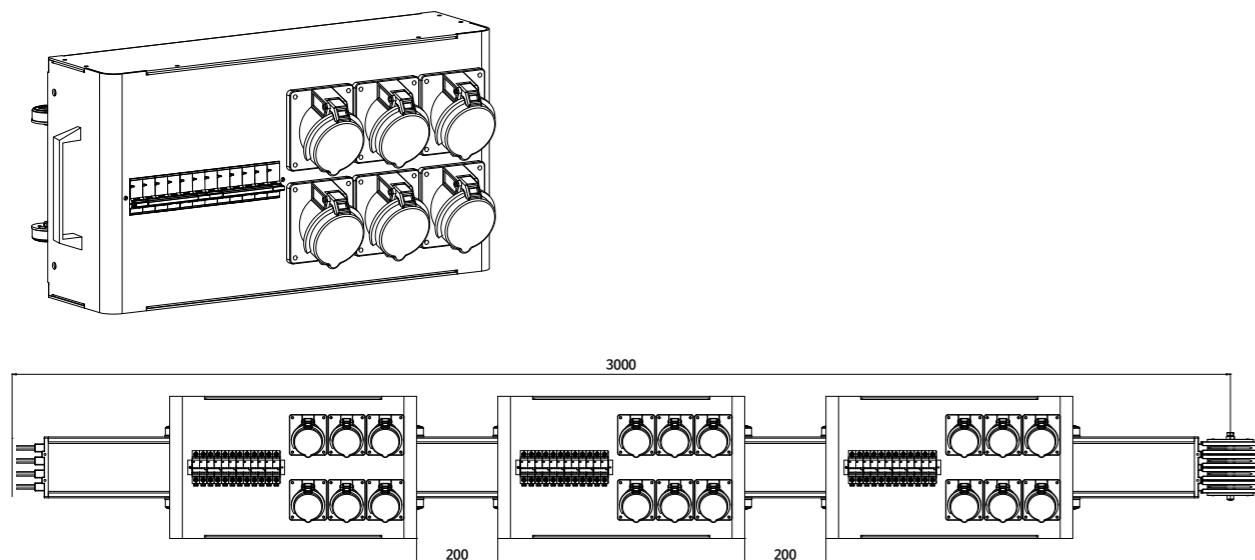

Receptacle



Item	Ampere	Voltage	Pole	Wire	Color
Connector	20, 30, 60, 100, 125A	250, 480, 600Vac	1, 3	3, 4, 5	Red, Blue, Yellow, Black
Plugs	20, 30, 60, 100, 125A	250, 480, 600Vac	1, 3	3, 4, 5	Red, Blue, Yellow, Black
Receptacle	16, 32, 63, 100, 125A	250, 480, 600Vac	1, 3	3, 4, 5	Red, Blue, Yellow, Black
Inlet	20, 30, 60, 100, 125A	250, 480, 600Vac	1, 3	3, 4, 5	Red, Blue, Yellow, Black

Breaker / Switch



CP

- Protection circuits for special mechanical equipment such as semiconductors and LCDs.
- For both AC/DC

Pole	Ampere	Voltage	kA
1	1, 2, 5, 7, 10, 15, 20, 25, 30A	250Vac/65Vdc	2.5
2			
3			
2	2, 3, 5, 10, 20, 30A	250Vac/125Vdc	2.5

MCB

- Protection circuits for mechanical facilities.
- Various accessories available. (AX, AL, SHT, OVT/UVT)



Pole	Ampere	Voltage	kA
1	1, 2, 3, 4, 6, 10, 16, 20, 25, 32, 40, 63A	240Vac/60Vdc	10
2		240/415Vac/125Vdc	
3			
4			

Installation

Vertical Installation

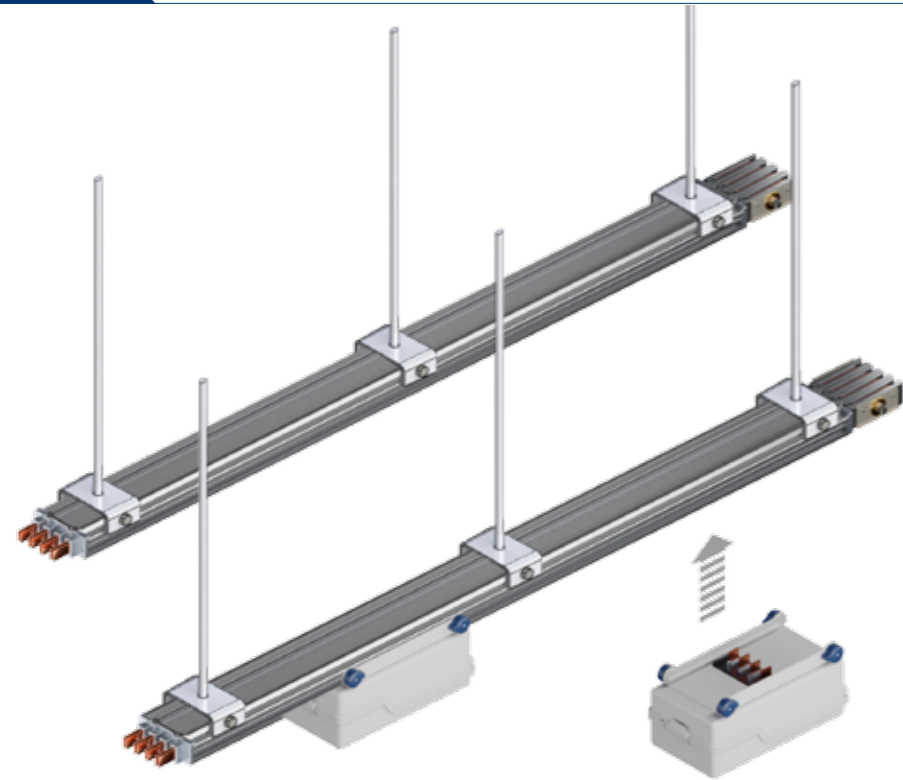

Horizontal Installation

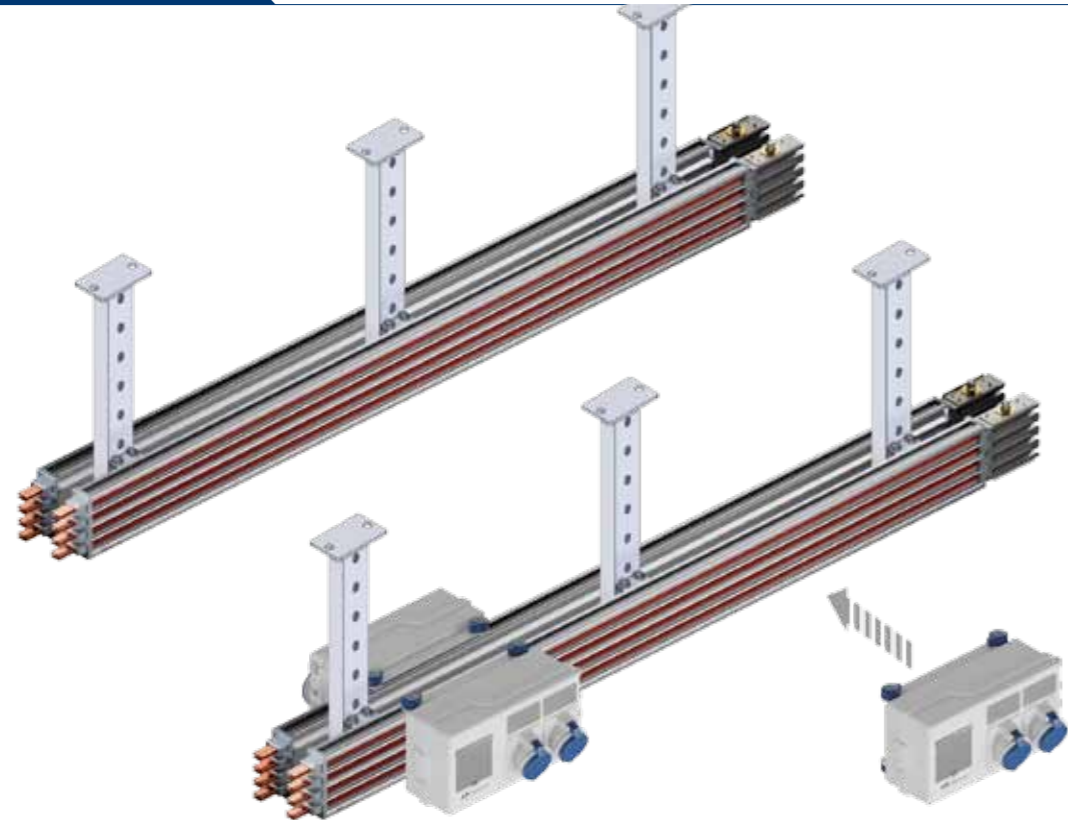

Feed in Unit

Consider two installation method depending on the space available.

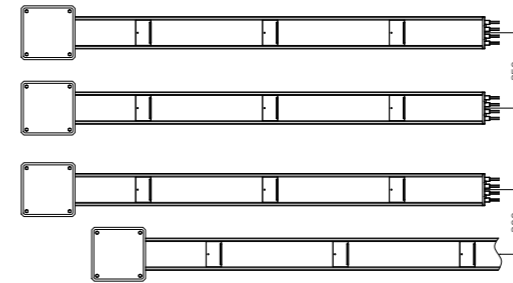

[Figure 1]



[Figure 2]

Busduct layout #1

Minimum distance required by Busway to withdraw cables. (2 receptacles)

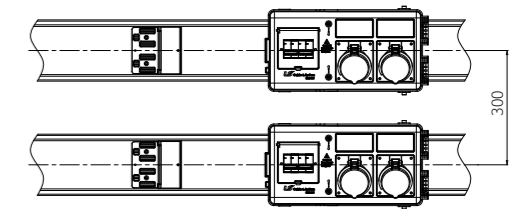

[Figure 3]

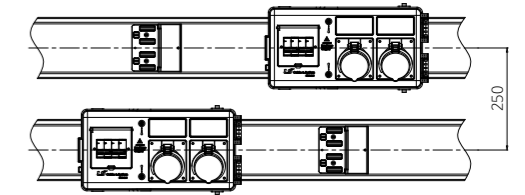

[Figure 4]

Busduct layout #2

Minimum distance required by Busway to withdraw cables. (3 receptacles)

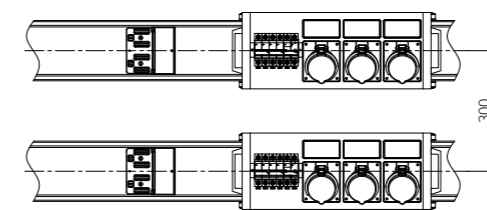

[Figure 5]

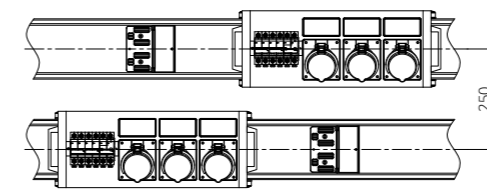

[Figure 6]

Busduct layout #3

Minimum distance required by Busway to withdraw cables. (6 receptacles)

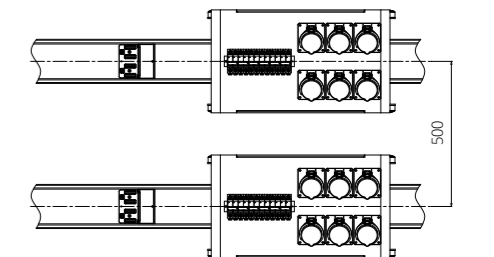

[Figure 7]

BPMS

Term of use

Usage Temperature	Storage Temperature	Usage Humidity	Ingress Protection	Standard
-10 - 50°C	-20 - 90°C	0 ~ 90% (On the condition that no condensation occurs)	34	IEC61000-4, KEMC1110, IEC 62053-22, UL 61010-1

Power Module



· Self activated power, Voltage measurement.

Model	Input	Output	Size	Weight	IP	Usage Enviroment
1	AC/DC 80-240V 15W	DC 5V, 10W	27(W)x 60(D) x 60(H)	200g	34	-10-50°C 0 - 90%
2	AC/DC 200-520V 15W	DC 24V, 7W	47(W)x 60(D) x 60(H)			

Display Module



Items	D110	
LCD	3inch, 350 x 160 pixel	
Input	Voltage	80-520V
	Operating power	DC 5V
	Power Consumption	4W
Communication method	Modbus	
Size (W x H x D)	Internal 24x95x55(mm)	
Weight		300g

Metering Module



Items	M101, M102, M103	M301, M302		
Connection Method	1P2W	3P3W, 3P4W		
Input	Voltage	PT	80-260V	80-260V
	Electric current	CT (Basic)	100-250A	100-250A
		CT (Split type)	0.1-80A	0.1-80A
	Frequency	50 / 60Hz	50 / 60Hz	
	Leakage Current	0.01-10A	0.01-10A	
	Temperature	0-120°C	0-120°C	
	D/I	Wet Contact	DC 24V	DC 24V
	Operation Power	DC 5V	DC 5V	
	Power Consumption	4W	4W	
Insulation resistance	DC 500M 10M 이상	DC 500M 10M 이상		
Power frequency withstand voltage	AC 2kV/1min	AC 2kV/1min		
Communication Method	Vertical communication method	Modbus-CAN	Modbus-CAN	
	Internal communication method	Modbus	Modbus	
Size (WxHxD)	27 x 60 x 60(mm)	27 x 60 x 60(mm)		
Weight	200g	200g		

Protocol	Items	Specification	Notes
Modbus-CAN	Media	RS-485	-
	Communication range	Max. 1.2km	
	Communication speed	25000bps	
Modbus	Media	RS-485	Connected to Display Module
	Communication range	Max. 5m	-
	Communication speed	9600bps	

Measuring Elenent	Display Range	Precision	Notes
V	0-520V	±0.5%	line to line, phase voltage
A	0 ~ 2000A	±0.5%	Phase current
PF	0 ~ 100%	±0.5%	+lagging, -leading
F	45 - 65Hz	±0.02Hz	
W	0 - 9999MW	±0.5%	
VAR	0 - 9999MVAR	±0.5%	
VA	0 - 9999MVA	±0.5%	
WH	0 - 9999MWH	±0.5%	
VARH	0 - 9999MVARH	±0.5%	
PHASE	0 - 360°	±0.2°	
Current Demand	0 ~ 2000A	±0.5%	
Power Demand	0 - 9999MW	±0.5%	
Current THD	0 ~ 100%	±1%	
Voltage THD	0 ~ 100%	±1%	
Current TDD	0 ~ 100%	±1%	
Unbalance factor	0 ~ 100%	±0.5%	
Sag/Swell	0 ~ 100%	±0.5%	
Leakage Current	0.05 - 1.2A	±0.005A	
Temperature	-20 - 150°C	±2°C	
D/I	On / Off	-	

BPMS

I/O Module



Items	D/I-in	D/I-out	A/I	Notes
Channel	4ch	4ch	4ch	
Input Range	Dry Contact	AC/DC 0-250V	4-20mA	
Isolation Voltage	DC 500V	DC 1000V	DC 500V	
Size (W x H x D)	27 x 60 x 60(mm)			
Weight	200g	200g	200g	

Comm. Module



Items	PLC	Wireless	Notes
Protocol	PLC	Zigbee	
Voltage range	110-500, 50/60Hz	-	
Size (W x H x D)	27 x 60 x 60(mm)		
Weight	200g	200g	

DCU(Data Concentrated Unit)



Items	D400	Notes
Upper level	Protocol	Modbus-TCP
	Communication Speed	10/100Mbps
	Client	4
Lower level	Protocol	Modbus-RTU/CAN
	Communication Speed	Mosbus: 9600/19200 bps CAN: 25000 bps
	Communication Channel	2Ch
	Node	48EA/Ch, Max 96EA
Operating Power	AC/DC 86-264	
Power consumption	5W	
Size (W x H x D)	150 x 80 x 50(mm)	
Weight	280g	

Current Transformer



· Normal



· Split

Items	Normal Type	Split Type	Notes
Standard	100-1250A	-125A	
Rated Voltage	1st: 1250A / 2nd: 5A	1st: 80A / 2nd: 333mV	
Burden	5VA	1VA	
Precision	Class 1.0	Class 1.0	
Weight	200g	200g	

Comm. Cable



· RS 485



· LAN

Items	Specification	Terminal	Communication Range	Notes
RS485	UL2919	3P Plugable Connector	1.200m	
LAN	UTP/STP	RJ-45	100m	

Touch P/C



Items	Touch Panel	Notes
LCD	15" TFT Color 1024x768dot	
Memory	DDR4 4GB	
HDD	256GB SSD	
Operating power	AC 90-264V	
Power consumption	220W	
OS	Windows 7	
Size (W x H x D)	368 x 292 x 113(mm)	

GLOBAL NETWORK

More than 60 Factories,
Sales and Production Sites
in 20 Countries.

- Factory
- Sales office
- Branch office

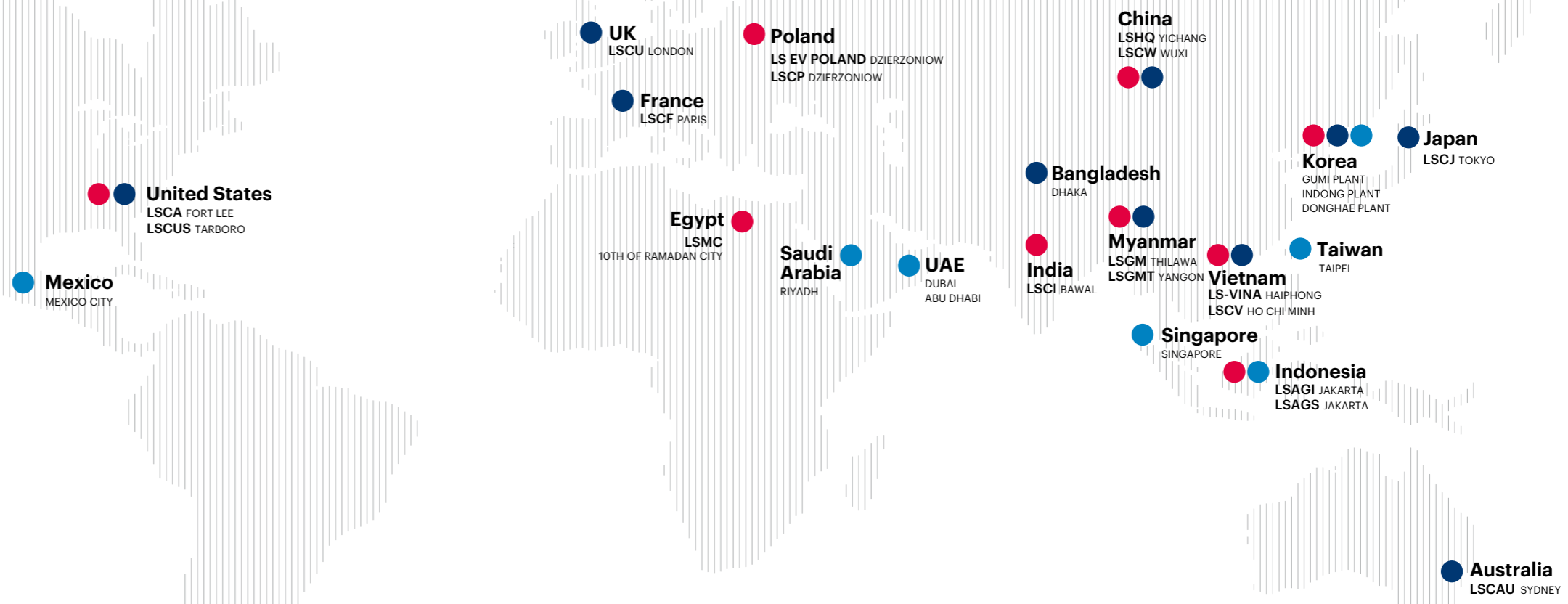

KOREA



Gumi Plant
EHV / MV / LV cable
UTP, Coaxial cable
SCR, Magnet wire
Overhead cable, Bus duct



Indong Plant
Optical fiber
Optical cable



Donghae Plant
Submarine cable
Industrial specialty cable

CHINA



LSHQ(Yichang)
EHV / MV / LV cable
Industrial specialty cable



LSCW(Wuxi)
Industrial devices cable
Automotive cable
Harness & module
Aluminum, Bus duct

VIETNAM



LS-VINA(Haiphong)
EHV / MV / LV cable
SCR, ACSR
Overhead cable



LSCV(HO Chi Minh)
MV / LV cable
UTP, Optical cable
Overhead cable

INDIA



LSCI(Bawal)
EHV / MV / LV cable
Coaxial cable
Overhead cable

USA



LSCUS(Tarboro)
MV / LV cable
Control, Instrument cable

POLAND



LS EV Poland./LSCP (Dzierzoniow)
Automotive battery components
Optical cable